



# DS3146/DS3148/DS31412

## 6-/8-/12-Channel DS3/E3 Framers

[www.maxim-ic.com](http://www.maxim-ic.com)

### GENERAL DESCRIPTION

The DS3146/DS3148/DS31412 (DS314x) devices include all necessary circuitry to frame and format up to 12 separate DS3 or E3 channels. Each framer in these devices is independently configurable to support M23 DS3, C-Bit Parity DS3, or G.751 E3. The framers interface to a variety of line interface units (LIUs), microprocessor buses, and other system components without glue logic. Each DS3/E3 framer has its own HDLC controller, FEAC controller, and BERT, as well as full support for error detection and generation, performance monitoring, and loopbacks.

### APPLICATIONS

SONET/SDH Muxes  
 PDH Muxes  
 Digital Cross-Connect Systems  
 Access Concentrators  
 ATM and Frame Relay Equipment  
 Routers

### FUNCTIONAL DIAGRAM

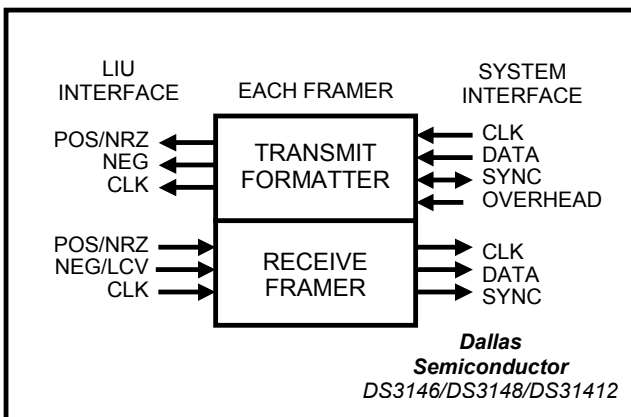

### FEATURES

- 6/8/12 Independent DS3/E3 Framers on a Single Die
- Framing and Formatting to M23 DS3, C-Bit Parity DS3, and G.751 E3
- LIU Interface can be Binary (NRZ) or Dual-Rail (POS/NEG)
- B3ZS/HDB3 Encoder and Decoder
- Generate and Detect DS3/E3 Alarms
- Integrated HDLC Controller for Each Channel
- Integrated FEAC Controller for Each Channel
- Integrated Bit Error-Rate Tester (BERT) for Each Channel
- Large Performance-Monitoring Counters
- Line, Diagnostic, and Payload Loopbacks
- Externally Controlled Transmit Overhead Insertion Port
- Support External Timing or Loop-Timing
- Framers can be Powered Down When Not Used
- 8-Bit Processor Port Supports Muxed or Nonmuxed Bus Operation (Intel or Motorola)
- 3.3V Supply with 5V Tolerant I/O
- 349-Pin, 27mm x 27mm BGA Package
- IEEE 1149.1 JTAG Support

### ORDERING INFORMATION

PART	NO. OF FRAMERS	TEMP RANGE	PIN-PACKAGE
DS3146	6	0°C to +70°C	349 BGA
DS3146N	6	-40°C to +85°C	349 BGA
DS3148	8	0°C to +70°C	349 BGA
DS3148N	8	-40°C to +85°C	349 BGA
DS31412	12	0°C to +70°C	349 BGA
DS31412N	12	-40°C to +85°C	349 BGA

Pin Configurations appear at end of data sheet.

**Note:** Some revisions of this device may incorporate deviations from published specifications known as errata. Multiple revisions of any device may be simultaneously available through various sales channels. For information about device errata, click here: [www.maxim-ic.com/errata](http://www.maxim-ic.com/errata).

## TABLE OF CONTENTS

<b>1. BLOCK DIAGRAM</b> .....	<b>6</b>
<b>2. APPLICATION EXAMPLE</b> .....	<b>6</b>
<b>3. MAIN FEATURES</b> .....	<b>7</b>
<b>4. STANDARDS COMPLIANCE</b> .....	<b>8</b>
<b>5. PIN DESCRIPTION</b> .....	<b>9</b>
5.1 TRANSMIT FORMATTER LIU INTERFACE PINS .....	9
5.2 RECEIVE FRAMER LIU INTERFACE PINS .....	9
5.3 TRANSMIT FORMATTER SYSTEM INTERFACE PINS .....	10
5.4 RECEIVE FRAMER SYSTEM INTERFACE PINS .....	12
5.5 CPU BUS INTERFACE PINS .....	14
5.6 JTAG INTERFACE PINS.....	14
5.7 SUPPLY, TEST, AND RESET PINS.....	14
<b>6. REGISTERS</b> .....	<b>15</b>
6.1 STATUS REGISTER DESCRIPTION .....	17
<b>7. FUNCTIONAL DESCRIPTION</b> .....	<b>18</b>
7.1 PIN INVERSIONS AND FORCE HIGH/LOW .....	18
7.2 TRANSMITTER LOGIC DESCRIPTION .....	18
7.2.1 <i>Transmit Clock</i> .....	18
7.2.2 <i>Loss-of-Clock Detection</i> .....	19
7.3 RECEIVER LOGIC.....	19
7.4 ERROR INSERTION.....	20
7.5 LOOPBACKS .....	20
7.5.1 <i>Line Loopback</i> .....	20
7.5.2 <i>Diagnostic Loopback</i> .....	20
7.5.3 <i>Payload Loopback</i> .....	20
7.5.4 <i>BERT and Loopback Interaction</i> .....	20
7.6 COMMON AND LINE INTERFACE REGISTERS .....	22
7.6.1 <i>Master Status Register (MSR)</i> .....	29
7.7 DS3/E3 FRAMER .....	33
7.8 DS3/E3 PERFORMANCE ERROR COUNTERS .....	43
7.9 BERT.....	46
7.10 HDLC CONTROLLER .....	54
7.10.1 <i>Receive Operation</i> .....	54
7.10.2 <i>Transmit Operation</i> .....	55
7.11 FEAC CONTROLLER .....	63

<b>8. OPERATION DETAILS .....</b>	<b>68</b>
8.1 RESET .....	68
8.2 DS3 AND E3 MODE CONFIGURATION .....	68
8.3 LIU AND SYSTEM INTERFACE CONFIGURATION.....	68
8.4 LOOPBACK MODES .....	69
8.5 TRANSMIT OVERHEAD INSERTION.....	69
<b>9. JTAG INFORMATION.....</b>	<b>70</b>
9.1 JTAG TAP CONTROLLER STATE MACHINE .....	70
9.2 JTAG INSTRUCTION REGISTER AND INSTRUCTIONS.....	72
9.3 JTAG SCAN REGISTERS.....	73
<b>10. DC ELECTRICAL CHARACTERISTICS .....</b>	<b>74</b>
<b>11. AC TIMING CHARACTERISTICS .....</b>	<b>75</b>
11.1 SYSTEM INTERFACE TIMING .....	75
11.2 MICROPROCESSOR INTERFACE TIMING.....	78
11.3 JTAG INTERFACE TIMING .....	83
<b>12. PIN ASSIGNMENTS .....</b>	<b>84</b>
<b>13. PACKAGE INFORMATION.....</b>	<b>88</b>
<b>14. THERMAL INFORMATION .....</b>	<b>89</b>
<b>15. REVISION HISTORY.....</b>	<b>89</b>

## LIST OF FIGURES

Figure 1-1. Block Diagram .....	6
Figure 2-1. Application Example: 12-Port Unchannelized DS3/E3 Card .....	6
Figure 5-1. Transmit Formatter Timing .....	11
Figure 5-2. Receive Framer Timing .....	13
Figure 6-1. Status Register Interrupt Flow .....	17
Figure 7-1. Transmit Data Block Diagram .....	18
Figure 7-2. Transmit Clock Block Diagram .....	19
Figure 7-3. Receiver Block Diagram .....	19
Figure 7-4. MSR Status Bit Interrupt Signal Flow .....	32
Figure 7-5. T3E3SR Status Bit Interrupt Signal Flow .....	40
Figure 7-6. BERT Status Bit Interrupt Signal Flow .....	51
Figure 7-7. HDLC Status Bit Interrupt Signal Flow .....	60
Figure 7-8. FEAC Status Bit Interrupt Signal Flow .....	66
Figure 9-1. JTAG Block Diagram .....	70
Figure 9-2. JTAG TAP Controller State Machine .....	71
Figure 11-1. Data Path Timing Diagram .....	76
Figure 11-2. TCCLK Data Path Timing Diagram .....	76
Figure 11-3. Line Loopback Timing Diagram .....	77
Figure 11-4. SCLK Clock Timing .....	78
Figure 11-5. Microprocessor Interface Timing Diagram (Nonmultiplexed) .....	79
Figure 11-6. Microprocessor Interface Timing Diagram (Multiplexed) .....	81
Figure 11-7. JTAG Interface Timing Diagram .....	83
Figure 12-1. DS3146 Pin Configuration .....	85
Figure 12-2. DS3148 Pin Configuration .....	86
Figure 12-3. DS31412 Pin Configuration .....	87

## LIST OF TABLES

Table 4-A. Applicable Telecommunications Standards .....	8
Table 6-A. Register Map .....	15
Table 6-B. Status Register Set Example .....	17
Table 7-A. BERT/Loopback Interaction—Payload Bits .....	20
Table 7-B. BERT/Loopback Interaction—Overhead Bits .....	21
Table 7-C. Common Line Interface Register Map .....	22
Table 7-D. DS3/E3 Framer Register Map .....	33
Table 7-E. DS3 Alarm Criteria .....	41
Table 7-F. E3 Alarm Criteria .....	41
Table 7-G. BERT Register Map .....	46
Table 7-H. HDLC Register Map .....	55
Table 7-I. FEAC Register Map .....	64
Table 9-A. JTAG Instruction Codes .....	72
Table 9-B. JTAG ID Code .....	73
Table 10-A. Recommended DC Operating Conditions .....	74
Table 10-B. DC Electrical Characteristics .....	74
Table 11-A. Data Path Timing .....	75
Table 11-B. TCCLK Data Path Timing .....	75
Table 11-C. Line Loopback Timing .....	77
Table 11-D. Microprocessor Interface Timing .....	78
Table 11-E. JTAG Interface Timing .....	83
Table 12-A. Global Pin Assignments (Sorted by Signal Name) .....	84
Table 12-B. Per-Framer Pin Assignments (Sorted by Signal Name) .....	84
Table 13-A. Thermal Properties, Natural Convection .....	89
Table 13-B. Theta-JA ( $\theta_{JA}$ ) vs. Airflow .....	89

# 1. BLOCK DIAGRAM

Figure 1-1. Block Diagram

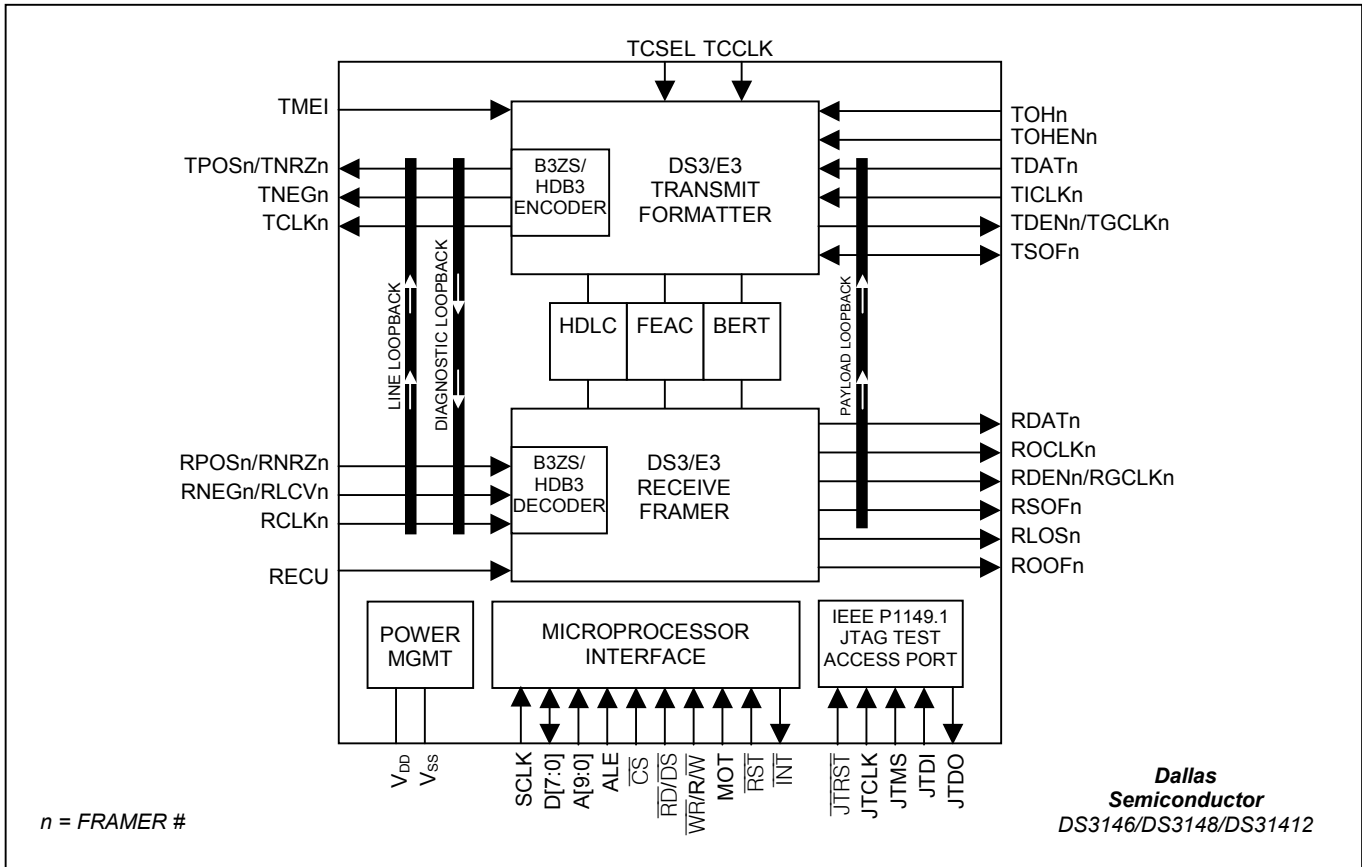

# 2. APPLICATION EXAMPLE

Figure 2-1. Application Example: 12-Port Unchannelized DS3/E3 Card

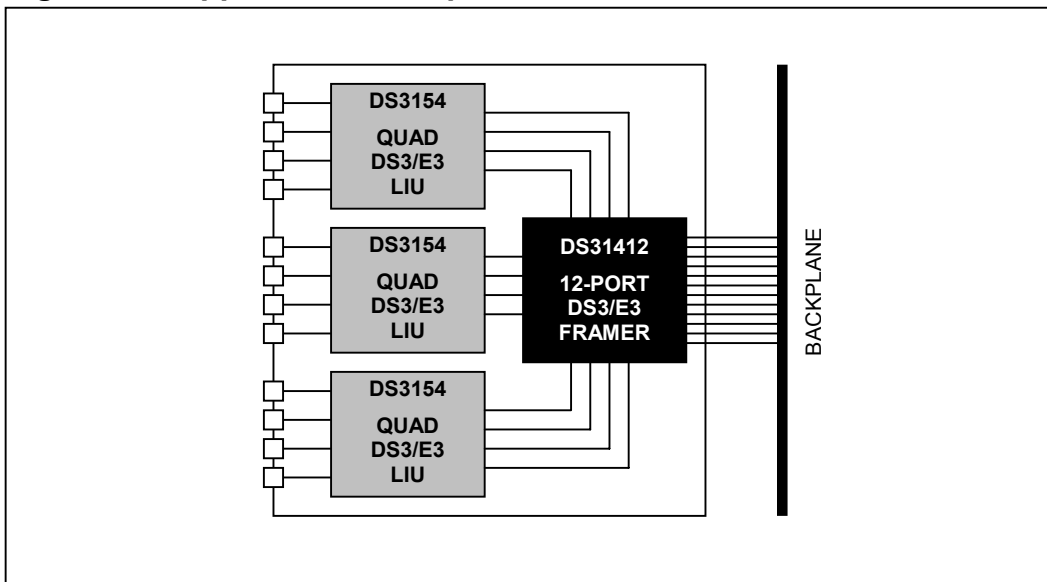

### 3. MAIN FEATURES

#### General

- LIU Interfaces can be Either Dual-Rail (POS/NEG/CLK) or Binary (DAT/CLK/LCV)
- Support Gapped 52MHz Clock Rates
- Optional B3ZS/HDB3 Encoder and Decoder
- Clock, Data, and Control Signals can be Inverted to Allow a Glueless Interface to Other Devices
- Detection of Loss-of-Transmit Clock and Loss-of-Receive Clock
- Manual or Automatic One-Second Update of Performance Monitoring Counters
- Each Framer can be Put Into Low-Power Standby Mode When Not Being Used

#### Receive Framer

- Frame Synchronization for M23 DS3, C-Bit Parity DS3, and G.751 E3
- Optional B3ZS/HDB3 Decoding
- Detects RAI, AIS, and DS3 Idle Signal
- Detects and Accumulates Bipolar Violations (BPV), Line-Code Violations (CVs), Excessive Zeros (EXZ), F-Bit Errors, M-Bit Errors, FAS Errors, P-Bit Parity Errors, CP-Bit Parity Errors, and Far-End Block Errors (FEBE)
- Detect Loss-of-Signal (LOS), Out-of-Frame (OOF), Severely Errored Frame Event (SEF), Change-of-Frame Alignment (COFA), Receipt of B3ZS/HDB3 Codewords, and DS3 Application ID Status
- E3 National Bit (Sn) is Forwarded to a Status Register Bit, the HDLC Controller, and the FEAC Controller

#### Transmit Formatter

- Frame Insertion for M23 DS3, C-Bit Parity DS3, and G.751 E3
- Optional B3ZS/HDB3 Encoding
- Clear-Channel Formatter Pass-Through Mode
- Generate RAI, AIS, and DS3 Idle Signals
- Automatic or Manual FEBE Insertion
- Support Automatic or Manual Insertion of BPVs, CVs, Excessive Zeros, F-Bit Errors, M-Bit Errors, FAS Errors, P-Bit Parity Errors, and CP-Bit Parity Errors
- E3 National Bit (Sn) can be Sourced from a Control Register, the HDLC Controller, or the FEAC Controller
- Any Overhead Bit Position can be Externally Overridden in the Transmit Formatter Using the Transmit Overhead Enable (TOHEN) and the Transmit Overhead Input (TOH). This Feature Enables External Control Over Unused Overhead Bits for Proprietary Signaling Applications.
- Optional Common Transmit Clock-Input Pin

#### HDLC Controller

- Designed to Handle Multiple LAPD Messages with Minimal Host Processor Intervention
- 256-Byte Receive and Transmit FIFOs are Large Enough to Handle the Three DS3 PMDL Messages (Path ID, Idle Signal ID, and Test Signal ID) that are Sent and Received Once per Second
- Handles All the Normal Layer 2 Tasks Such As Zero Stuffing/Destuffing, CRC and Abort Generation/Checking, Flag Generation/ Detection, and Byte Alignment
- Programmable High and Low Watermarks for the Transmit and Receive FIFOs
- Terminates the Path Maintenance Data Link in DS3 C-Bit Parity mode and Optionally the Sn-Bit in E3 Mode

#### FEAC Controller

- Designed to Handle Multiple FEAC Codewords with Minimal Host Processor Intervention
- Receive FEAC Automatically Validates Incoming Codewords and Stores Them in a 4-Byte FIFO
- Transmit FEAC can be Configured to Send One Codeword, One Codeword Continuously, or Two Different Codewords Back-to-Back to Send DS3 Line Loopback Commands
- Terminates the FEAC Channel in DS3 C-Bit Parity Mode and Optionally the Sn Bit in E3 Mode

#### BERT

- Generates and Detects Pseudorandom Patterns  $2^{15} - 1$ ,  $2^{20} - 1$  (QRSS),  $2^{23} - 1$ , and  $2^{31} - 1$  as well as Repetitive Patterns from 1 to 32 Bits in Length
- Supports Pattern Insertion/Extraction in Either Payload Only or Full Bandwidth
- Large 24-Bit Error Counter Allows Testing to Proceed for Long Periods Without Host Processor Intervention
- Errors can be Inserted in the Generated BERT Patterns for Diagnostic Purposes (Single Bit Errors or Specific Bit-Error Rates)

#### Loopback

- Diagnostic Loopback (Transmit to Receive)
- Line Loopback (Receive to Transmit)
- Payload Loopback

#### Microprocessor Interface

- Multiplexed or Nonmultiplexed 8-Bit Processor Port
- Intel and Motorola Bus Compatible
- Global Reset-Input Pin
- Global Interrupt-Output Pin

## 4. STANDARDS COMPLIANCE

**Table 4-A. Applicable Telecommunications Standards**

SPECIFICATION	TITLE
<b>ANSI</b>	
T1.107–1995	<i>Digital Hierarchy—Formats Specification</i>
T1.231–1997	<i>Digital Hierarchy—Layer 1 In-Service Digital Transmission Performance Monitoring</i>
T1.404–1994	<i>Network-to-Customer Installation—DS3 Metallic Interface Specification</i>
<b>ITU–T</b>	
G.703	<i>Physical/Electrical Characteristics of Hierarchical Digital Interfaces, 1991</i>
G.751	<i>Digital Multiplex Equipment Operating at the Third-Order Bit Rate of 34,368kbps and the Fourth-Order Bit Rate of 139,264kbps and Using Positive Justification, 1993</i>
G.775	<i>Loss-of-Signal (LOS) and Alarm Indication Signal (AIS) Defect Detection and Clearance Criteria, November 1994</i>
G.823	<i>The Control of Jitter and Wander within Digital Networks that are Based on the 2048kbps Hierarchy, 1993</i>
O.151	<i>Error Performance Measuring Equipment Operating at the Primary Rate and Above, October 1992</i>
O.161	<i>In-Service Code Violation Monitors for Digital Systems, 1984</i>
<b>IETF</b>	
RFC 2469	<i>Definition of Managed Objects for the DS3/E3 Interface Type, Network Working Group Request for Comments, January 1999</i>
<b>TELCORDIA</b>	
GR-499-CORE	<i>Transport Systems Generic Requirements (TSGR): Common Requirements, Issue 1, December 1995</i>
GR-820-CORE	<i>Generic Digital Transmission Surveillance, Issue 1, November 1994</i>
TR-TSY-000009	<i>Asynchronous Digital Multiplexes Requirements and Objectives, Issue 1, May 1986</i>
TR-TSY-000191	<i>Alarm Indication Signal Requirements and Objectives, Issue 1, May 1986</i>



## 5. PIN DESCRIPTION

### 5.1 Transmit Formatter LIU Interface Pins

NAME	TYPE	FUNCTION
TPOS/ TNRZ	O	Transmit Positive Data Output/Transmit NRZ Data Output. If BIN = 0 in the <a href="#">MC1</a> register, the LIU interface is in dual-rail (POS/NEG) mode. In this mode, the transmit formatter outputs the serial data stream in alternate mark inversion (AMI) format. TPOS = 1 signals an external LIU to drive a positive pulse on the line, while TNEG = 1 tells the LIU to drive a negative pulse on the line. If BIN = 1, the LIU interface is in binary (NRZ) mode. In this mode, the transmit formatter outputs the serial data stream in binary format on the TNRZ pin. TNRZ = 1 indicates a 1 in the data stream, while TNRZ = 0 indicates a 0. If TCLKI = 0 in the <a href="#">MC5</a> register, data is clocked out of the formatter on the rising edge of TCLK. If TCLKI = 1, data is clocked out on the falling edge of TCLK. <a href="#">MC5</a> :TPOSH = 1 forces TPOS/TNRZ high. <a href="#">MC5</a> :TPOSI = 1 inverts the polarity of TPOS/TNRZ. Setting both TPOSH = 1 and TPOSI = 1 forces TPOS/TNRZ low.
TNEG	O	Transmit Negative Data Output. If BIN = 0 in the <a href="#">MC1</a> register, the LIU interface is in dual-rail (POS/NEG) mode. In this mode, the transmit formatter outputs the serial data stream in AMI format. TPOS = 1 signals an external LIU to drive a positive pulse on the line, while TNEG = 1 tells the LIU to drive a negative pulse on the line. If BIN = 1, the LIU interface is in binary (NRZ) mode. In this mode the transmit formatter outputs the serial data stream in binary format on the TNRZ pin, and TNEG is driven low. If TCLKI = 0 in the <a href="#">MC5</a> register, data is clocked out of the formatter on the rising edge of TCLK. If TCLKI = 1, data is clocked out on the falling edge of TCLK. <a href="#">MC5</a> :TNEGH = 1 forces TNEG high. <a href="#">MC5</a> :TNEGI = 1 inverts the polarity of TNEG. Setting both TNEGH = 1 and TNEGI = 1 forces TNEG low.
TCLK	O	Transmit Clock Output. TCLK is used to clock data out of the transmit formatter on TPOS/TNEG (dual-rail LIU interface mode) or TNRZ (binary LIU interface mode). If TCLKI = 0 in the <a href="#">MC5</a> register, data is clocked out of the formatter on the rising edge of TCLK. If TCLKI = 1, data is clocked out on the falling edge of TCLK. TCLK is normally a buffered (and optionally inverted) version of TICLK. When either line loopback or payload loopback is active, TCLK is a buffered (and optionally inverted) version of RCLK. When a clock is not present on TICLK and <a href="#">MC1</a> :LOTCMC = 1, TCLK is a buffered (and optionally inverted) version of RCLK.

### 5.2 Receive Framer LIU Interface Pins

NAME	TYPE	FUNCTION
RPOS/ RNRZ	I	Receive Positive Data Input/Receive NRZ Data Input. If BIN = 0 in the <a href="#">MC1</a> register, the LIU interface is in dual-rail (POS/NEG) mode. In this mode, the framer clocks in the serial data stream in AMI format. RPOS = 1 from an external LIU indicates a positive pulse was received on the line; RNEG = 1 from the LIU indicates a negative pulse was received on the line. If BIN = 1, the framer is in binary (NRZ) LIU interface mode. In this mode the framer clocks in the serial data stream in binary format on the RNRZ pin. RNRZ = 1 indicates a 1 in the data stream; RNRZ = 0 indicates a 0 in the data stream. If RCLKI = 0 in the <a href="#">MC5</a> register, data is clocked into the framer on the rising edge of RCLK. If RCLKI = 1, data is clocked in on the falling edge of RCLK. <a href="#">MC5</a> :RPOSI = 1 inverts the polarity of RPOS/RNRZ.
RNEG/ RLCV	I	Receive Negative Data Input/Receive Line-Code Violation Input. If BIN = 0 in the <a href="#">MC1</a> register, the LIU interface is in dual-rail (POS/NEG) mode. In this mode, the framer clocks in the serial data stream in AMI format. RPOS = 1 from an external LIU indicates a positive pulse was received on the line, while RNEG = 1 from the LIU indicates a negative pulse was received on the line. If BIN = 1, the framer is in binary (NRZ) LIU interface mode. In this mode the framer clocks in the serial data stream in binary format on the RNRZ pin and line code violations on the RLCV pin. If RCLKI = 0 in the <a href="#">MC5</a> register, data is clocked into the framer on the rising edge of RCLK. If RCLKI = 1, data is clocked in on the falling edge of RCLK. <a href="#">MC5</a> :RNEGI = 1 inverts the polarity of RNEG/RLCV. In binary LIU interface mode, when <a href="#">MC5</a> :RNEGI = 0, the BPV counter (registers <a href="#">BPVCR1</a> and <a href="#">BPVCR2</a> ) counts RCLK cycles when RLCV = 1. When <a href="#">MC5</a> :RNEGI = 1, the BPV counter counts RCLK cycles when RLCV = 0.
RCLK	I	Receive Clock Input. RCLK is used to clock data into the receive framer on RPOS/RNEG (dual-rail LIU interface mode) or RNRZ (binary LIU interface mode). If RCLKI = 0 in the <a href="#">MC5</a> register, data is clocked into the framer on the rising edge of RCLK. If RCLKI = 1, data is clocked in on the falling edge of RCLK. RCLK is normally accurate to within $\pm 20$ ppm when sourced from an LIU, but the framer can also accept a gapped clock up to 52MHz on RCLK, such as those commonly sourced from ICs that map/demap DS3 and E3 to/from SONET/SDH.

### 5.3 Transmit Formatter System Interface Pins

NAME	TYPE	FUNCTION
TICLK	I	Transmit Input Clock. TICLK samples the TDAT, TDEN/TGCLK, TSOF, TOH, and TOHEN input pins. TICLK accepts a smooth clock or a gapped clock up to 52MHz. When the framer is connected to an LIU without a jitter attenuator, TICLK should be an ungapped, transmission-quality DS3 or E3 clock ( $\pm 20$ ppm, low jitter) to meet the frequency accuracy and jitter requirements for transmission. The default active sampling edge of TICLK is the rising edge. To make the negative edge the active sampling edge, set <a href="#">MC3:TICLKI</a> = 1. When the TCSEL pin is high (common transmit clock mode) TICLK is not used and should be wired low.
TDAT	I	Transmit Data Input. In C-Bit Parity DS3 mode, payload bits are clocked into the transmit formatter on TDAT. In M23 DS3 mode and E3 mode, payload bits, stuff opportunity bits and C bits are clocked in on TDAT. TDAT is sampled on the active sampling edge of TICLK. The default active sampling edge of TICLK is the rising edge. To make the negative edge the active sampling edge, set <a href="#">MC3:TICLKI</a> = 1. TDAT can be internally inverted by setting <a href="#">MC3:TDATI</a> = 1.
TDEN/ TGCLK	O	Transmit Data Enable/Transmit Gapped Clock. The transmit formatter can be configured to either output a data enable (TDEN) or a gapped clock (TGCLK). In data enable mode, TDEN goes active when payload data should be made available on the TDAT input pin and inactive when the formatter is inserting framing overhead. In gapped clock mode, TGCLK acts as a demand clock for the TDAT input, toggling for each payload bit position and not toggling when the formatter is inserting framing overhead. In DS3 mode, overhead data is defined as the M bits, F bits, C bits, X bits, and P bits. In E3 mode, overhead data is defined as the FAS word, RAI bit, and Sn bit (bits 1 to 12). To configure the transmit formatter for data enable mode, set <a href="#">MC3:TDENMS</a> = 0. To configure for gapped clock operation, set <a href="#">MC3:TDENMS</a> = 1. TDEN is normally active high; to make TDEN active low, set <a href="#">MC3:TDENI</a> = 1. TGCLK normally is the same polarity as TICLK; to invert TGCLK, set <a href="#">MC3:TDENI</a> = 1. In the transmit pass-through mode ( <a href="#">T3E3CR1:TPT</a> = 1), TDEN/TGCLK continues to mark the payload positions in the original frame established before TPT was activated. This pin can also be made to output a constant transmit clock by setting <a href="#">MC2:TCCLK</a> = 1. This constant clock is useful for certain applications that need to use the TOH and TOHEN pins during payload loopback.
TSOF	O/I	Transmit Start-of-Frame. TSOF indicates the DS3 or E3 frame boundary on the outgoing transmit data stream. When TSOFC = 1 in the <a href="#">MC3</a> register, TSOF is an output and pulses high for one TICLK cycle during the last bit of each DS3 or E3 frame. When TSOFC = 0, TSOF is an input and is sampled to set the transmit DS3 or E3 frame boundary. See <a href="#">Figure 5-1</a> for functional timing. Note that the reset default is for TSOF to be an input. Some applications require an external pullup or pulldown resistor on TSOF to keep it from floating during power-up and reset. TSOF is normally active high. Set <a href="#">MC3:TSOFI</a> = 1 to make TSOF active low. If transmit pass-through (TPT) mode is enabled ( <a href="#">T3E3CR1:TPT</a> = 1) and TSOF is an output, TSOF continues to mark the original frame position that was established before TPT activation.
TOHEN	I	Transmit Overhead Enable. Together the TOHEN and TOH pins make a simple, general-purpose transmit-overwrite port. This port is usually used to overwrite overhead bit positions (such as unused C bits in C-Bit Parity mode), but payload bits can be overwritten as well. During any clock cycle in which TOHEN is active, the formatter sources the TOH pin rather than the TDAT pin or the internal overhead generation logic. In DS3 mode, parity is not recalculated if any payload bits are overwritten. TOHEN can be internally inverted by setting <a href="#">MC3:TOHENI</a> = 1.
TOH	I	Transmit Overhead Data. Together the TOHEN and TOH pins make a simple, general-purpose transmit-overwrite port. This port is usually used to overwrite overhead bit positions (such as unused C bits in C-Bit Parity mode), but payload bits can be overwritten as well. During any clock cycle in which TOHEN is active, the formatter sources the TOH pin rather than the TDAT pin or the internal overhead generation logic. TOH can be inverted by setting <a href="#">MC3:TOHI</a> = 1.
TMEI	I	Transmit Manual-Error Insert. This pin is used to manually control the insertion of errors in the DS3 or E3 frame structure or the line coding. This pin is enabled when MEIMS = 1 in the <a href="#">T3E3EIC</a> register. A single error is normally inserted on the rising edge of TMEI. The other bits in the <a href="#">T3E3EIC</a> register control which types of errors are inserted. All framers on the device share this pin.
TCCLK	I	Transmit Common Clock. This signal can be used by all of the framers as a common transmit clock, replacing the signals on the TICLK <sub>n</sub> pins. Wiring the TCSEL pin high enables TCCLK. If TCCLK is enabled, the TICLK <sub>n</sub> control bit in the MC3 register can be used to provide an inverted version of this signal to the transmit formatter on a per framer basis. The timing relationships between the transmit clock and the transmit formatter signals changes slightly compared to the timing using the TICLK <sub>n</sub> pins. See <a href="#">Section 11</a> for more information.
TCSEL	I	Transmit Common Clock Select. This signal is used to select the clock on the TCCLK pin as the common transmit clock for all the framers, replacing the clocks on the TICLK <sub>n</sub> pins. When this pin is high, the TCCLK signal clocks all the framers. When this pin is low, the TICLK <sub>n</sub> signals clock the framers individually.

**Figure 5-1. Transmit Formatter Timing**

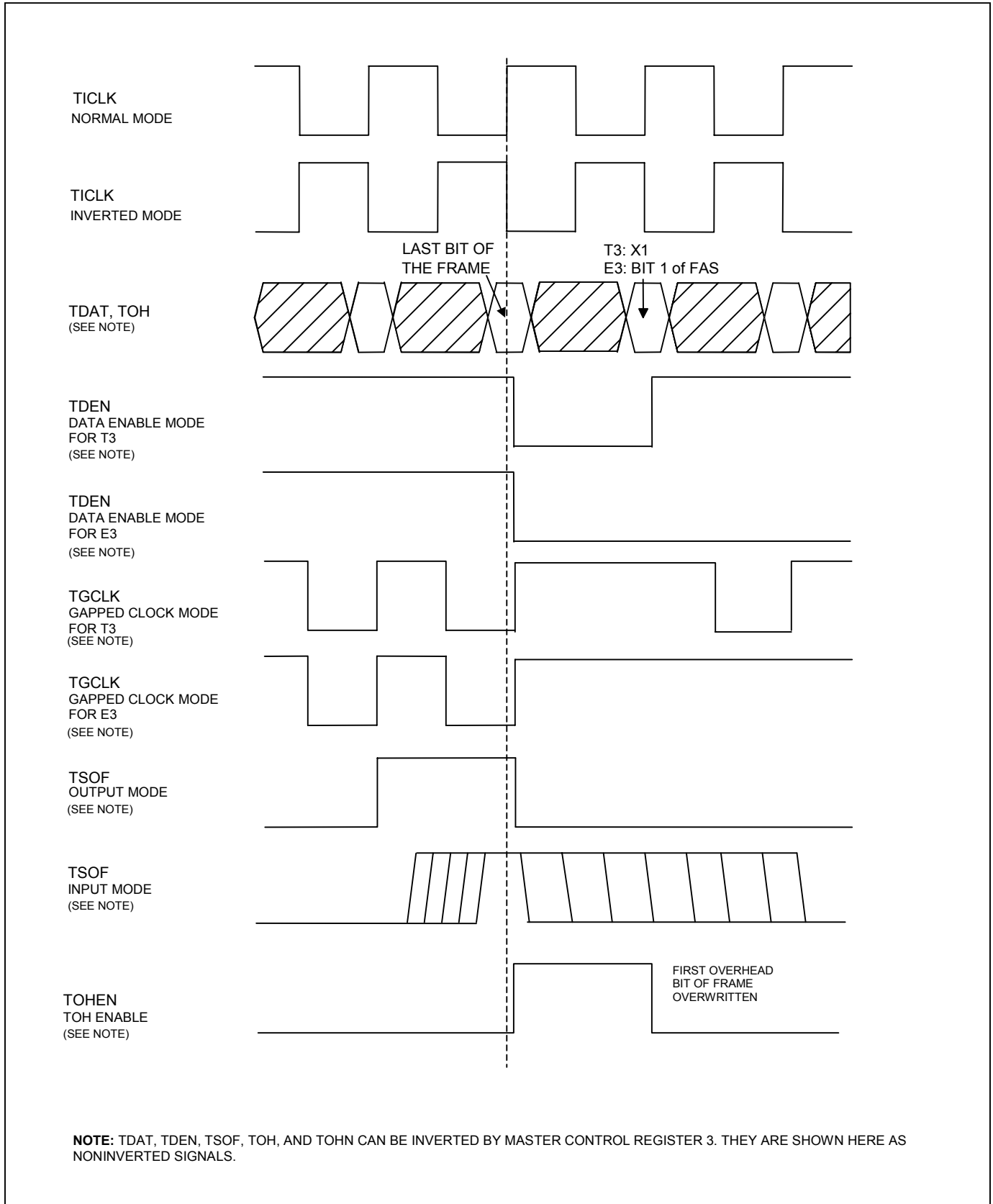

## 5.4 Receive Framer System Interface Pins

NAME	TYPE	FUNCTION
ROCLK	O	Receive Output Clock. ROCLK is used to clock data out of the receive framer on RDAT. ROCLK is normally a buffered (and optionally inverted) version of RCLK. When diagnostic loopback is active, ROCLK is a buffered (and optionally inverted) version of TICLK. If <a href="#">MC4:ROCLKI</a> = 0, data is clocked out of the framer on the rising edge of ROCLK. If <a href="#">MC4:ROCLKI</a> = 1, data is clocked out on the falling edge of ROCLK.
RDAT	O	Receive Data Output. The incoming DS3/E3 data stream is serially clocked out of the receive framer on the RDAT pin. RDAT is normally updated on the rising edge of ROCLK. To output data on the falling edge of ROCLK, set <a href="#">MC4:ROCLKI</a> = 1. To internally invert RDAT, set <a href="#">MC4:RDATI</a> = 1. To force RDAT high, set <a href="#">MC4:RDATH</a> = 1. To force RDAT low, set <a href="#">MC4:RDATH</a> = 1.
RDEN/ RGCLK	O	Receive Data Enable/Receive Gapped Clock. The receive framer can be configured to either output a data enable (RDEN) or a gapped clock (RGCLK). In data enable mode, RDEN goes active when payload data is available on the RDAT output pin and inactive when overhead data is present on the RDAT pin. In gapped clock mode, RGCLK acts as a payload data clock for the RDAT output, toggling for each payload bit position and not toggling for each framing overhead bit position. In DS3 mode, overhead data is defined as the M bits, F bits, C bits, X bits, and P bits. In E3 mode, overhead data is defined as the FAS word, RAI bit, and Sn bit (bits 1 to 12). To configure the receive framer for data enable mode, set <a href="#">MC4:RDENMS</a> = 0. To configure for gapped clock operation, set <a href="#">MC4:RDENMS</a> = 1. RDEN is normally active high; to make RDEN active low, set <a href="#">MC4:RDENI</a> = 1. RGCLK normally is the same polarity as RCLK; to invert RGCLK, set <a href="#">MC4:RDENI</a> = 1.
RSOF	O	Receive Start of Frame. RSOF indicates the DS3 or E3 frame boundary on the incoming receive data stream. RSOF pulses high for one TICLK cycle during the last bit of each DS3 or E3 frame. RSOF is normally active high. Set <a href="#">MC4:RSOFI</a> = 1 to make RSOF active low.
RLOS	O	Receive Loss of Signal. RLOS goes high when the receive framer is in a loss-of-signal (LOS) state. It remains high as long as the LOS state persists and returns low when the framer exits the LOS state. See <a href="#">Table 7-E</a> and <a href="#">Table 7-F</a> for details on the set and clear criteria for this pin. LOS status is also available through the LOS status bit in the <a href="#">T3E3SR</a> register.
ROOF	O	Receive Out of Frame. ROOF goes high when the receive framer is in an out-of-frame (OOF) state. It remains high as long as the OOF state persists and returns low when the framer synchronizes. See <a href="#">Table 7-E</a> and <a href="#">Table 7-F</a> for details on the set and clear criteria for this pin. OOF status is also available through the OOF status bit in the <a href="#">T3E3SR</a> register.
RECU	I	Receive Error-Counter Update Strobe. Through the AECU control bit in the <a href="#">MC1</a> register, the device can be configured to use this asynchronous input to initiate an update of the internal error counters in all the framers on the device. A 0-to-1 transition on the RECU pin causes the device to load the error counter registers with the latest internal error counts. This signal must be returned low before a subsequent update of the error counters can occur. After toggling the RECU pin, the host processor must wait at least 100ns before reading the error counter registers to allow the device time to load the registers. This signal is logically ORed with the MECU control bit in <a href="#">MC1</a> . If this signal is not used, it should be wired low.

**Figure 5-2. Receive Framer Timing**

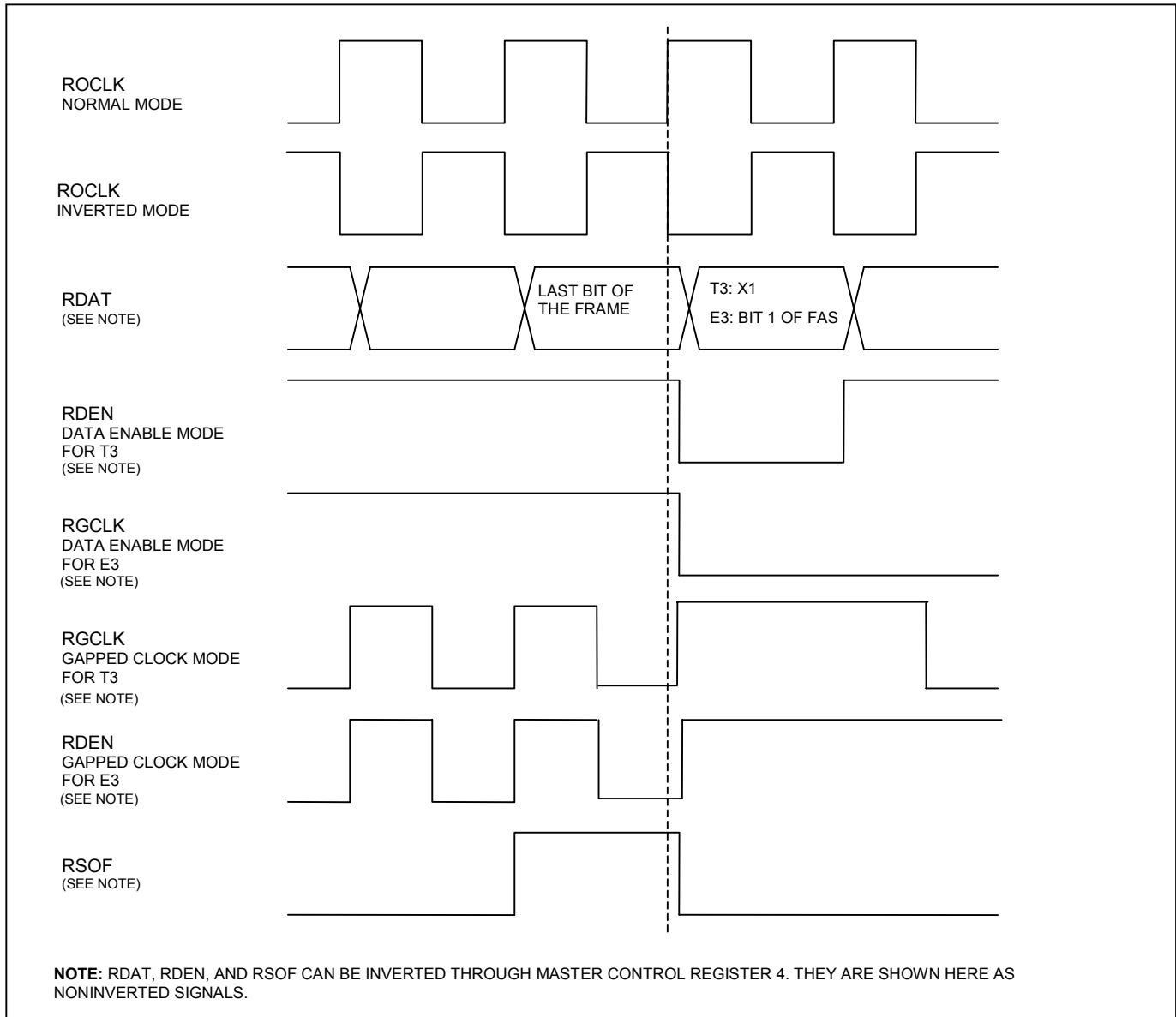

## 5.5 CPU Bus Interface Pins

NAME	TYPE	FUNCTION
MOT	I	Motorola Bus Mode Select. This pin controls whether the CPU bus operates in Intel mode or in Motorola mode. 0 = CPU bus is in Intel mode 1 = CPU bus is in Motorola mode
D[7:0]	I/O	CPU Bus Data. The host processor accesses the device's internal registers through this bus. These pins are outputs during reads and inputs otherwise. D7 is the MSB; D0 is the LSB.
A[11:0]	I	CPU Bus Address. The host processor specifies the address of the internal register to be accessed. In multiplexed bus applications, the A[7:0] pins should be connected to the D[7:0] pins, and A[11:0] must have a valid register address when the ALE pin goes low. A11 is the MSB; A0 is the LSB.
ALE	I	CPU Bus Address Latch Enable. This pin controls the address latch for the A[11:0] inputs. When ALE is high, the latch is transparent. On the falling edge of ALE, the latch samples and holds the A[11:0] inputs. In nonmultiplexed bus applications, ALE should be wired high. In multiplexed bus applications, A[7:0] should be connected to D[7:0], and the falling edge of ALE latches the address.
$\overline{CS}$	I	CPU Bus Chip Select, Active Low. The host processor selects the device for read or write access by driving this pin low.
$\overline{WR}$ (R/W)	I	CPU Bus Write Enable (CPU Bus Read/Write Select), Active Low. In Intel mode (MOT = 0), $\overline{WR}$ controls write accesses to the device. In Motorola mode (MOT = 1), R/W specifies whether a read or a write access is to occur.
$\overline{RD}$ ( $\overline{DS}$ )	I	CPU Bus Read Enable (CPU Bus Data Strobe), Active Low. In Intel mode (MOT = 0), $\overline{RD}$ controls read accesses to the device. In Motorola mode (MOT = 1), $\overline{DS}$ controls both read and write accesses to the device, while the R/W pin specifies the type of access.
$\overline{INT}$	O	CPU Bus Interrupt, Open Drain, Active Low. This pin is driven low by the device if one or more unmasked interrupt sources within the device are active. $\overline{INT}$ remains low until the interrupt is serviced or masked.
SCLK	I	System Clock. An ungapped clock with frequency between 33MHz and 52MHz must be provided to this pin to run certain logic in the CPU bus port. The use of this clock allows the transmit and receive clocks (TICLK and RCLK) to be gapped, if desired, without affecting the CPU bus timing. This pin can be connected to TICLK or RCLK if the signal on one of those pins is an ungapped clock.

## 5.6 JTAG Interface Pins

NAME	TYPE	FUNCTION
JTCLK	I	JTAG IEEE 1149.1 Test Serial Clock. This pin is used to shift data into JTDI on the rising edge and out of JTDO on the falling edge. If not used, this pin should be wired high.
JTDI	I	JTAG IEEE 1149.1 Test Serial-Data Input (Internal 10k $\Omega$ Pullup). Test instructions and data are clocked in on this pin on the rising edge of JTCLK. If not used, JTDI should be left unconnected or driven high.
JTDO	O	JTAG IEEE 1149.1 Test Serial-Data Output. Test instructions are clocked out of this pin on the falling edge of JTCLK. If not used, JTDO should be left open-circuited. This pin is in tri-state mode after JTRST is activated.
$\overline{JTRST}$	I	JTAG IEEE 1149.1 Test Reset (Active-Low, Internal 10k $\Omega$ Pullup). This pin is used to asynchronously reset the test access port controller. At power-up, $\overline{JTRST}$ must be driven low and then high. This action sets the device into the boundary scan bypass mode, allowing normal device operation. If boundary scan is not used, this pin should be held low.
JTMS	I	JTAG IEEE 1149.1 Test Mode Select (Internal 10k $\Omega$ Pullup). This pin is sampled on the rising edge of JTCLK and is used to place the test port into the various defined IEEE 1149.1 states. If not used, JTMS should be left unconnected or driven high.

## 5.7 Supply, Test, and Reset Pins

NAME	TYPE	FUNCTION
$\overline{RST}$	I	Global Hardware Reset (Active Low). When this pin is driven low, all of the framers in the device are reset and all of the internal registers are forced to their default values. The device is held in the reset state as long as this pin is low. The clocks (TICLK and RCLK) must be stable and in spec before this pin is driven high. The device registers can be configured for operation after the reset is deactivated.
$\overline{TEST}$	I	Factory Test Enable (Active-Low, Internal 10k $\Omega$ Pullup). This pin should be left open-circuited.
$\overline{HI_Z}$	I	High-Z Control (Active-Low, Internal 10k $\Omega$ Pullup). When this pin is low and $\overline{JTRST}$ is low, all outputs go to the high-impedance mode. This pin can be left open-circuited by the user.
V <sub>SS</sub>	—	Digital Ground Reference. All V <sub>SS</sub> pins should be wired together.
V <sub>DD</sub>	—	Digital Positive Supply. 3.3V ( $\pm 5\%$ ). All V <sub>DD</sub> pins should be wired together.

## 6. REGISTERS

The framers are memory-mapped as follows:

Framer 1 (000h to 0FFh)	Framer 5 (400h to 4FFh)	Framer 9 (800h to 8FFh)
Framer 2 (100h to 1FFh)	Framer 6 (500h to 5FFh)	Framer 10 (900h to 9FFh)
Framer 3 (200h to 2FFh)	Framer 7 (600h to 6FFh)	Framer 11 (A00h to AFFh)
Framer 4 (300h to 3FFh)	Framer 8 (700h to 7FFh)	Framer 12 (B00h to BFFh)

DS31412 has 12 framers and uses address space 000h to BFFh. DS3148 has eight framers and uses address space 000h to 7FFh. DS3146 has six framers and uses address space 000h to 5FFh. DS3146 does not have address pin A[11].

[Table 6-A](#) shows the framer register map. Bits that are underlined are read-only bits. Bits that are marked “N/A” are undefined. Addresses that are not listed in [Table 6–A](#) are undefined. Undefined registers and bits are reserved for future enhancements and must always be written with logic 0 and ignored when read.

The device [ID](#) register is mapped into address 00h of every framer on the chip. Similarly, the [ISR1](#) and [ISR2](#) registers are mapped into addresses 06h and 07h of every framer on the chip. All other registers are unique to each framer, including the reset (RST) register bit in [MC1](#), which only resets the framer it is associated with, not the entire chip.

**Table 6-A. Register Map**

ADDR [7:0]	REGISTER	BIT 7	BIT 6	BIT 5	BIT 4	BIT 3	BIT 2	BIT 1	BIT 0
00h	<a href="#">ID</a>	<a href="#">ID7</a>	<a href="#">ID6</a>	<a href="#">ID5</a>	<a href="#">ID4</a>	<a href="#">ID3</a>	<a href="#">ID2</a>	<a href="#">ID1</a>	<a href="#">ID0</a>
01h	<a href="#">MC1</a>	LOTMC	ZCSD	BIN	MECU	AECU	TUA1	DISABLE	RST
02h	<a href="#">MC2</a>	OSTCS	TCCLK	N/A	RZSF	N/A	DLB	LLB	PLB
03h	<a href="#">MC3</a>	TDENMS	TSOFC	TOHENI	TOHI	TSOFI	TICLKI	TDATI	TDENI
04h	<a href="#">MC4</a>	RDENMS	ROOFI	RLOSI	RDATH	RSOFI	ROCLKI	RDATI	RDENI
05h	<a href="#">MC5</a>	RNEGI	RPOSI	RCLKI	TNEG	TPOSH	TNEGI	TPOSI	TCLKI
06h	<a href="#">ISR1</a>	<a href="#">INT8</a>	<a href="#">INT7</a>	<a href="#">INT6</a>	<a href="#">INT5</a>	<a href="#">INT4</a>	<a href="#">INT3</a>	<a href="#">INT2</a>	<a href="#">INT1</a>
07h	<a href="#">ISR2</a>	N/A	N/A	N/A	N/A	<a href="#">INT12</a>	<a href="#">INT11</a>	<a href="#">INT10</a>	<a href="#">INT9</a>
08h	<a href="#">MSR</a>	<a href="#">LORC</a>	<a href="#">LOTCL</a>	<a href="#">T3E3SR</a>	<a href="#">FEAC</a>	<a href="#">HDLC</a>	<a href="#">BERT</a>	<a href="#">COVF</a>	N/A
09h	<a href="#">MSRL</a>	LORCL	LOTCL	N/A	N/A	N/A	N/A	COVFL	OSTL
0Ah	<a href="#">MSRIE</a>	LORCIE	LOTCLIE	<a href="#">T3E3SRIE</a>	<a href="#">FEACIE</a>	<a href="#">HDLCIE</a>	<a href="#">BERTIE</a>	<a href="#">COVFIE</a>	<a href="#">OSTIE</a>
10h	<a href="#">T3E3CR1</a>	E3SnC1	E3SnC0	T3IDLE	TRAI	TAIS	TPT	CBEN	DS3M
11h	<a href="#">T3E3CR2</a>	FRESYNC	N/A	TFEBE	AFEBED	ECC	FECC1	FECC0	E3CVE
12h	<a href="#">T3E3EIC</a>	MEIMS	FBEIC1	FBEIC0	FBEI	T3CPBEI	T3PBEI	EXZI	BPVI
18h	<a href="#">T3E3SR</a>	N/A	N/A	<a href="#">SEF</a>	<a href="#">T3IDLE</a>	<a href="#">RAI</a>	<a href="#">AIS</a>	<a href="#">OOF</a>	<a href="#">LOS</a>
19h	<a href="#">T3E3SRL</a>	COFAL	N/A	SEFL	T3IDLEL	RAIL	AISL	OOFL	LOSL
1Ah	<a href="#">T3E3SRIE</a>	COFAIE	N/A	SEFIE	T3IDLEIE	RAIIE	AISIE	OOFIE	LOSIE
1Bh	<a href="#">T3E3IR</a>	<a href="#">RUA1</a>	<a href="#">T3AIC</a>	<a href="#">E3Sn</a>	N/A	EXZL	MBEL	FBEL	ZSCDL
20h	<a href="#">BPVCR1</a>	<a href="#">BPV7</a>	<a href="#">BPV6</a>	<a href="#">BPV5</a>	<a href="#">BPV4</a>	<a href="#">BPV3</a>	<a href="#">BPV2</a>	<a href="#">BPV1</a>	<a href="#">BPV0</a>
21h	<a href="#">BPVCR2</a>	<a href="#">BPV15</a>	<a href="#">BPV14</a>	<a href="#">BPV13</a>	<a href="#">BPV12</a>	<a href="#">BPV11</a>	<a href="#">BPV10</a>	<a href="#">BPV9</a>	<a href="#">BPV8</a>
22h	<a href="#">EXZCR1</a>	<a href="#">EXZ7</a>	<a href="#">EXZ6</a>	<a href="#">EXZ5</a>	<a href="#">EXZ4</a>	<a href="#">EXZ3</a>	<a href="#">EXZ2</a>	<a href="#">EXZ1</a>	<a href="#">EXZ0</a>
23h	<a href="#">EXZCR2</a>	<a href="#">EXZ15</a>	<a href="#">EXZ14</a>	<a href="#">EXZ13</a>	<a href="#">EXZ12</a>	<a href="#">EXZ11</a>	<a href="#">EXZ10</a>	<a href="#">EXZ9</a>	<a href="#">EXZ8</a>
24h	<a href="#">FECR1</a>	<a href="#">FE7</a>	<a href="#">FE6</a>	<a href="#">FE5</a>	<a href="#">FE4</a>	<a href="#">FE3</a>	<a href="#">FE2</a>	<a href="#">FE1</a>	<a href="#">FE0</a>
25h	<a href="#">FECR2</a>	<a href="#">FE15</a>	<a href="#">FE14</a>	<a href="#">FE13</a>	<a href="#">FE12</a>	<a href="#">FE11</a>	<a href="#">FE10</a>	<a href="#">FE9</a>	<a href="#">FE8</a>
26h	<a href="#">PCR1</a>	<a href="#">PE7</a>	<a href="#">PE6</a>	<a href="#">PE5</a>	<a href="#">PE4</a>	<a href="#">PE3</a>	<a href="#">PE2</a>	<a href="#">PE1</a>	<a href="#">PE0</a>
27h	<a href="#">PCR2</a>	<a href="#">PE15</a>	<a href="#">PE14</a>	<a href="#">PE13</a>	<a href="#">PE12</a>	<a href="#">PE11</a>	<a href="#">PE10</a>	<a href="#">PE9</a>	<a href="#">PE8</a>
28h	<a href="#">CPCR1</a>	<a href="#">CPE7</a>	<a href="#">CPE6</a>	<a href="#">CPE5</a>	<a href="#">CPE4</a>	<a href="#">CPE3</a>	<a href="#">CPE2</a>	<a href="#">CPE1</a>	<a href="#">CPE0</a>
29h	<a href="#">CPCR2</a>	<a href="#">CPE15</a>	<a href="#">CPE14</a>	<a href="#">CPE13</a>	<a href="#">CPE12</a>	<a href="#">CPE11</a>	<a href="#">CPE10</a>	<a href="#">CPE9</a>	<a href="#">CPE8</a>

ADDR [7:0]	REGISTER	BIT 7	BIT 6	BIT 5	BIT 4	BIT 3	BIT 2	BIT 1	BIT 0
2Ah	<a href="#">FEBCR1</a>	<u>FEBE7</u>	<u>FEBE6</u>	<u>FEBE5</u>	<u>FEBE4</u>	<u>FEBE3</u>	<u>FEBE2</u>	<u>FEBE1</u>	<u>FEBE0</u>
2Bh	<a href="#">FEBCR2</a>	<u>FEBE15</u>	<u>FEBE14</u>	<u>FEBE13</u>	<u>FEBE12</u>	<u>FEBE11</u>	<u>FEBE10</u>	<u>FEBE9</u>	<u>FEBE8</u>
30h	<a href="#">BCR1</a>	BM1	BM0	BENA	TINV	RINV	RESYNC	TC	LC
31h	<a href="#">BCR2</a>	N/A	PS2	PS1	PS0	RPL3	RPL2	RPL1	RPL0
32h	<a href="#">BCR3</a>	N/A	N/A	N/A	N/A	EIB2	EIB1	EIB0	SBE
33h	<a href="#">BCR4</a>	AWC7	AWC6	AWC5	AWC4	AWC3	AWC2	AWC1	AWC0
38h	<a href="#">BSR</a>	N/A	N/A	<u>RA1</u>	<u>RA0</u>	N/A	<u>BBCO</u>	<u>BECO</u>	<u>SYNC</u>
39h	<a href="#">BSRL</a>	N/A	N/A	RA1L	RA0L	BEDL	BBCOL	BECOL	SYNCL
3Ah	<a href="#">BSRIE</a>	N/A	N/A	N/A	N/A	BEDIE	BBCOIE	BECOIE	SYNCLIE
3Ch	<a href="#">BRPR1</a>	RP7	RP6	RP5	RP4	RP3	RP2	RP1	RP0
3Dh	<a href="#">BRPR2</a>	RP15	RP14	RP13	RP12	RP11	RP10	RP9	RP8
3Eh	<a href="#">BRPR3</a>	RP23	RP22	RP21	RP20	RP19	RP18	RP17	RP16
3Fh	<a href="#">BRPR4</a>	RP31	RP30	RP29	RP28	RP27	RP26	RP25	RP24
40h	<a href="#">BBCR1</a>	<u>BBC7</u>	<u>BBC6</u>	<u>BBC5</u>	<u>BBC4</u>	<u>BBC3</u>	<u>BBC2</u>	<u>BBC1</u>	<u>BBC0</u>
41h	<a href="#">BBCR2</a>	<u>BBC15</u>	<u>BBC14</u>	<u>BBC13</u>	<u>BBC12</u>	<u>BBC11</u>	<u>BBC10</u>	<u>BBC9</u>	<u>BBC8</u>
42h	<a href="#">BBCR3</a>	<u>BBC23</u>	<u>BBC22</u>	<u>BBC21</u>	<u>BBC20</u>	<u>BBC19</u>	<u>BBC18</u>	<u>BBC17</u>	<u>BBC16</u>
43h	<a href="#">BBCR4</a>	<u>BBC31</u>	<u>BBC30</u>	<u>BBC29</u>	<u>BBC28</u>	<u>BBC27</u>	<u>BBC26</u>	<u>BBC25</u>	<u>BBC24</u>
44h	<a href="#">BBEBCR1</a>	<u>BEC7</u>	<u>BEC6</u>	<u>BEC5</u>	<u>BEC4</u>	<u>BEC3</u>	<u>BEC2</u>	<u>BEC1</u>	<u>BEC0</u>
45h	<a href="#">BBEBCR2</a>	<u>BEC15</u>	<u>BEC14</u>	<u>BEC13</u>	<u>BEC12</u>	<u>BEC11</u>	<u>BEC10</u>	<u>BEC9</u>	<u>BEC8</u>
46h	<a href="#">BBEBCR3</a>	<u>BEC23</u>	<u>BEC22</u>	<u>BEC21</u>	<u>BEC20</u>	<u>BEC19</u>	<u>BEC18</u>	<u>BEC17</u>	<u>BEC16</u>
50h	<a href="#">HCR1</a>	RHR	THR	RID	TID	TFS	TZSD	TCRCI	TCRCD
51h	<a href="#">HCR2</a>	N/A	RHWMS2	RHWMS1	RHWMS0	N/A	TLWMS2	TLWMS1	TLWMS0
54h	<a href="#">HSR</a>	N/A	N/A	N/A	N/A	<u>RHWM</u>	<u>TLWM</u>	N/A	N/A
55h	<a href="#">HSRL</a>	ROVRL	RPEL	RPSL	RABTL	RHWML	TLWML	TUDRL	TENDL
56h	<a href="#">HSRIE</a>	ROVRIE	RPEIE	RPSIE	RABTIE	RHWMIIE	TLWMIIE	TUDRIE	TENDIE
57h	<a href="#">HIR</a>	N/A	N/A	<u>EMPTY</u>	<u>EMPTY</u>	<u>TFL3</u>	<u>TFL2</u>	<u>TFL1</u>	<u>TFL0</u>
5Ch	<a href="#">RHDLC1</a>	<u>D7</u>	<u>D6</u>	<u>D5</u>	<u>D4</u>	<u>D3</u>	<u>D2</u>	<u>D1</u>	<u>D0</u>
5Dh	<a href="#">RHDLC2</a>	N/A	N/A	N/A	N/A	<u>PS1</u>	<u>PS0</u>	<u>CBYTE</u>	<u>OBYTE</u>
5Eh	<a href="#">THDLC1</a>	D7	D6	D5	D4	D3	D2	D1	D0
5Fh	<a href="#">THDLC2</a>	N/A	N/A	N/A	N/A	N/A	N/A	N/A	TMEND
60h	<a href="#">FCR</a>	N/A	N/A	N/A	N/A	N/A	RFR	TFS1	TFS0
61h	<a href="#">FSR</a>	N/A	N/A	N/A	N/A	<u>RFFE</u>	<u>RFI</u>	<u>RFCD</u>	<u>TFI</u>
62h	<a href="#">FSRL</a>	N/A	N/A	N/A	RFFOL	RFFNL	RFIL	RFCDL	TFIL
63h	<a href="#">FSRIE</a>	N/A	N/A	N/A	RFFOIE	RFFNIE	RFIIE	RFCDIE	TFIIE
64h	<a href="#">TFEACA</a>	N/A	N/A	TFCA5	TFCA4	TFCA3	TFCA2	TFCA1	TFCA0
65h	<a href="#">TFEACB</a>	N/A	N/A	TFCB5	TFCB4	TFCB3	TFCB2	TFCB1	TFCB0
66h	<a href="#">RFEAC</a>	N/A	N/A	<u>RFF5</u>	<u>RFF4</u>	<u>RFF3</u>	<u>RFF2</u>	<u>RFF1</u>	<u>RFF0</u>

**Note 1.** Bits that are underlined are read-only bits. Bits that are marked "N/A" are unused and undefined.

**Note 2:** Framer addresses 70h, 71h, and 7Ch–7Fh are factory test registers. During normal operation, these registers should not be written and should be ignored when read.



## 6.1 Status Register Description

There are two types of bits used to build the status and information registers. The real-time status register bit indicates the state of the corresponding signal at the time it was read. The latched status register bit is set when the corresponding signal changes state (low-to-high, high-to-low, or both, depending on the bit). The latched status bit is cleared when written with logic 1 and is not set again until the corresponding signal changes state again.

The following is example host-processor pseudocode that checks to see if the BERT SYNC status has changed:

```

If ((BSRL and 01h) neq 0) then          // SYNCL bit is set
    BSRL = 01h                          // Clear SYNCL bit only
    If ((BSR and 01h) neq 0) then        // BERT has changed to in sync
        -----
    Else                                  // BERT has changed to out of sync
        -----

```

There are four suffixes used for status and information register names: SR for real-time status registers, SRL for latched status registers, SRIE for interrupt-enable registers, and IR for information registers. Latched status bits have the suffix "L" and interrupt-enable bits have the suffix "IE." The bits in the SR, SRL, and SRIE registers are arranged such that related real-time status, latched status, and interrupt-enable bits are located in the same bit position in neighboring registers. For example, [Table 6-B](#) shows that the real-time status bit SYNC, the latched status bit SYNCL, and the interrupt-enable bit SYNCIE are all located in bit 0 of their respective registers (BSR, BSRL, and BSRIE).

When set, most latched status register bits can cause an interrupt on the  $\overline{\text{INT}}$  pin if the corresponding interrupt-enable register bit is also set. Most latched status register bits have an associated real-time status register bit. Information registers can contain a mix of real-time and latched status bits, none of which can cause an interrupt.

**Table 6-B. Status Register Set Example**

REGISTER	BIT 7	BIT 6	BIT 5	BIT 4	BIT 3	BIT 2	BIT 1	BIT 0
<a href="#">BSR</a>	N/A	N/A	RA1	RA0	N/A	BBCO	BECO	SYNC
<a href="#">BSRL</a>	N/A	N/A	RA1L	RA0L	BEDL	BBCOL	BECOL	SYNCL
<a href="#">BSRIE</a>	N/A	N/A	N/A	N/A	BEDIE	BBCOIE	BECOIE	SYNCIE

**Figure 6-1. Status Register Interrupt Flow**

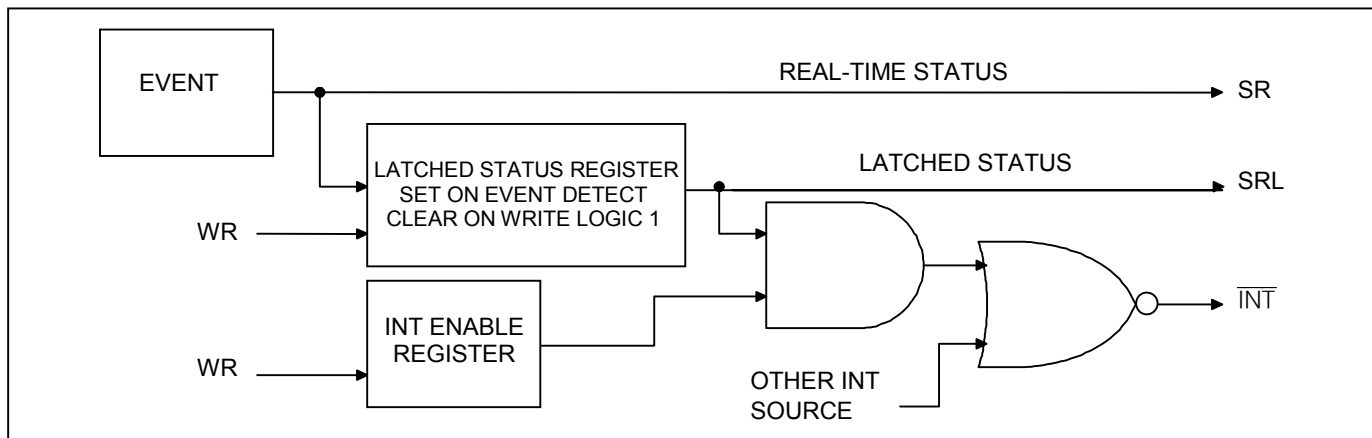

## 7. FUNCTIONAL DESCRIPTION

### 7.1 Pin Inversions and Force High/Low

Many of the input and output pins can be inverted and some output pins can be forced high or low (TPOS, TNEG, and RDAT). The inversion logic occurs at the input and output pads but before the JTAG control logic. The output pins that can be forced high can also be forced low by setting both the force high and invert bits for those pins.

### 7.2 Transmitter Logic Description

In the normal operating mode, the transmit section adds either DS3 or E3 framing overhead to the payload coming in on the TDAT input pin, then encodes the framed data in either HDB3 (E3 mode) or B3ZS (DS3 mode) and outputs the positive and negative pulse signals on TPOS and TNEG along with the transmit clock on TCLK. In line loopback mode (LLB bit in the [MC2](#) register), TPOS, TNEG, and TCLK are buffered versions of RPOS, RNEG, and RCLK. In payload loopback mode (PLB bit in the [MC2](#) register), payload is sourced from the receiver, framing overhead is added, and TCLK is a buffered version of RCLK. When a transmit alarm indication signal (TAIS) is generated, an E3 or DS3 AIS signal is generated on TPOS/TNEG independent of the signal being internally generated. This allows the device to be in diagnostic loopback (DLB) internally and simultaneously send AIS to the transmit LIU interface. The TAIS is generated when either the TAIS bit in the [T3E3CR1](#) register is set, or when there is a loss of transmit clock and the LOTCMC bit in the [MC1](#) register is set. The same applies to the generation of unframed all ones when the TUA1 bit in the [MC1](#) register is set. The TOHEN pin overwrites any of the data from TDAT, RDAT, the BERT (BPLD in BERT payload mode) or the transmit formatter with data from the TOH pin. The BERT signal in the unframed mode (BUFRM) is not overwritten with the TOH data. The data on TDAT (or RDAT in PLB mode) can be sent without adding internal overhead by setting the TPT (transmit passthrough) bit in the [T3E3CR1](#) register. In transmit pass-through mode, data from TOH can still overwrite data from TDAT or RDAT.

**Figure 7-1. Transmit Data Block Diagram**

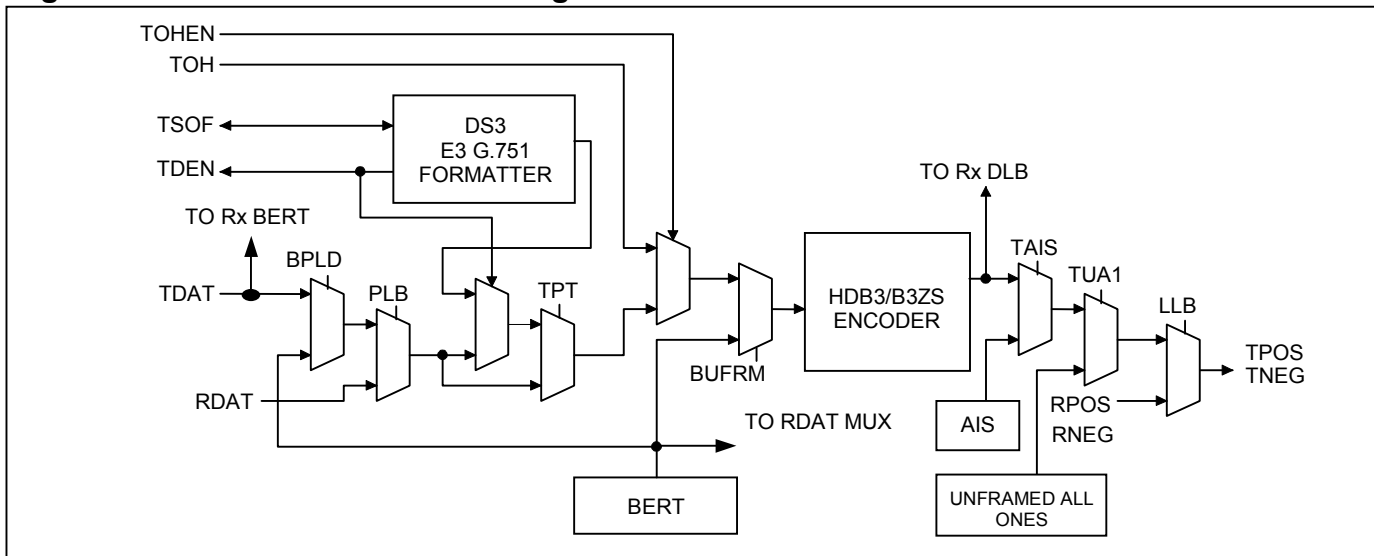

#### 7.2.1 Transmit Clock

The transmit clock on the TICLK pin is monitored for activity, and, if the clock signal is inactive for several SCLK cycles, then the loss of transmit clock (LOTC) status is set. The LOTC status is then cleared when the TICLK signal is active for a few cycles.

The internal transmit clock can be sourced from either the TICLK pin or the RCLK pin, depending on LOTC status, the LOTCMC control bit (in the [MC1](#) register), and payload loopback (PLB). Normally, the internal transmit clock is connected to the transmit input clock (TICLK) pin. When LOTC is detected and the LOTCMC bit is set, then the internal transmit clock is connected to the receive clock (RCLK). Also, if payload loopback (PLB) is selected, then the internal transmit clock is connected to RCLK. The TCLK output pin is sourced from the internal transmit clock except in line loopback mode (LLB), where TCLK is always sourced from RCLK.

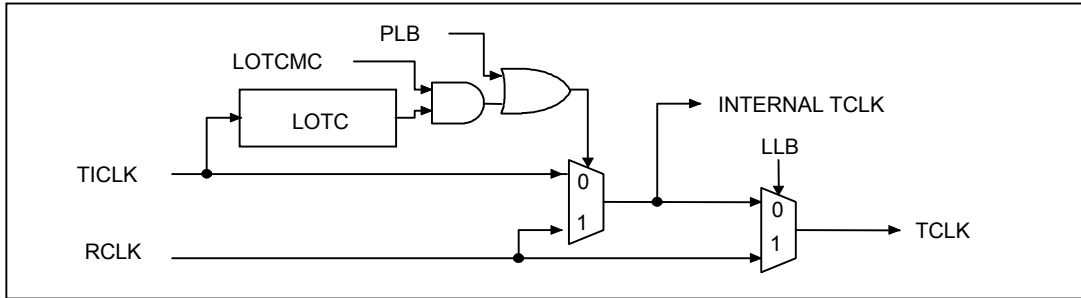
**Figure 7-2. Transmit Clock Block Diagram**

### 7.2.2 Loss-of-Clock Detection

The LOTC and LORC (loss-of-receive clock) status bits in the [MSR](#) register are set when the transmit (TCLK) and receive (RCLK) clocks are stopped, respectively. The clocks are monitored with the system clock (SCLK), which must be running for the loss-of-clock circuits to function properly. The LOTC and LORC status bits are set when TCLK or RCLK have been stopped high or low for between 9 and 21 clock periods (depending on SCLK frequency). The LOTC and LORC status bits are cleared after the device detects a few edges of the monitored clock.

### 7.3 Receiver Logic

In the normal operating mode, the signals on RPOS and RNEG are decoded as an HDB3 signal in E3 mode or as a B3ZS signal in DS3 mode and output on the RDAT pin. The input signal is monitored for loss-of-signal, bipolar violations, excessive zeros, AIS, unframed all ones and, after decoding, is sent to the BERT and synchronizer. When the synchronizer finds the framing pattern in the overhead bits, it clears the out-of-frame indication (ROOF) and aligns the start-of-frame (RSOF) and data-enable (RDEN) signals to the signal on RDAT. If the framing pattern is lost, then ROOF is set and the framing pattern is searched for again. While the framing pattern is being searched for, the RSOF and RDEN signals maintain the alignment with the last known position of the framing pattern. If a framing pattern is found in a new position, the RSOF and RDEN signals align with the new pattern position and the COFAL status bit is set in the [T3E3SRL](#) register. After reset, the RSOF and RDEN signals are generated, but have no relationship with any framing pattern until one is found. The signal on the ROOF pin can be monitored using the OOF bit in the [T3E3SR](#) register. When the diagnostic loopback mode is enabled using the DLB bit in the [MC2](#) register, RCLK, RPOS, and RNEG are replaced with TCLK, TPOS, and TNEG. This allows the framer and synchronizer logic to be checked in order to isolate a problem in the system. The BERT can monitor either the payload or the entire signal for expected test patterns.

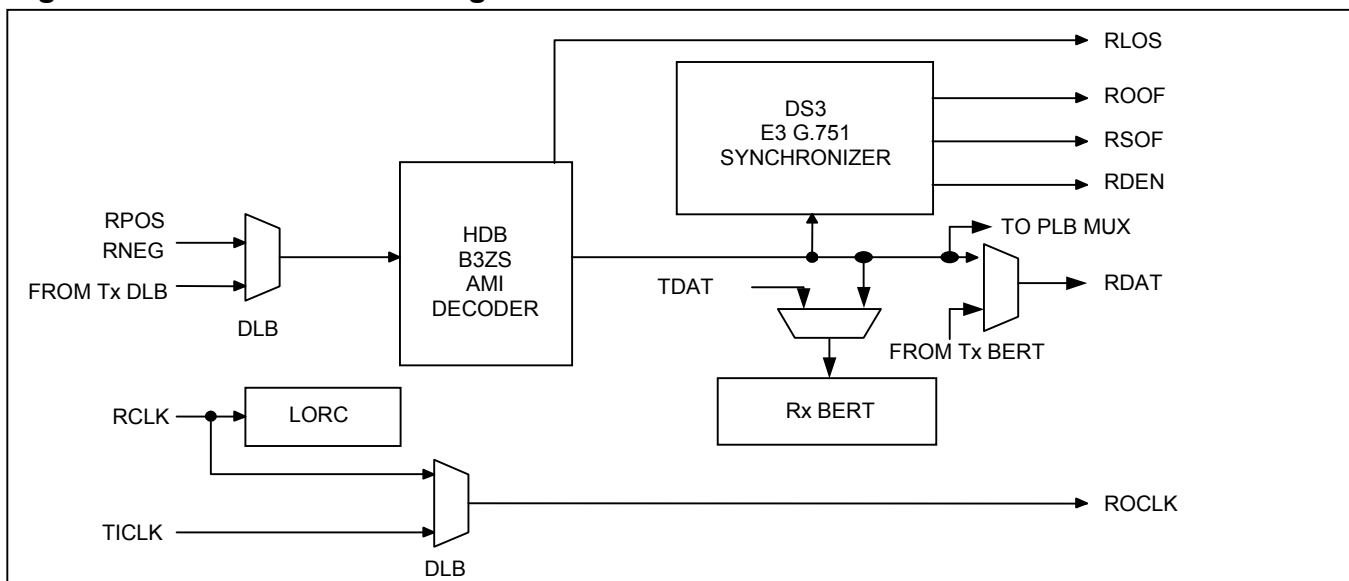
**Figure 7-3. Receiver Block Diagram**

## 7.4 Error Insertion

Errors can be created in the transmit overhead and line coding for diagnostic purposes. These errors do not cause any loss of data when created. The [T3E3EIC](#) error insertion register contains all of the control bits to create errors. The TMEI input pin can also be used to create errors.

## 7.5 Loopbacks

### 7.5.1 Line Loopback

The line loopback connects the incoming DS3/E3 data (RCLK, RPOS/RNRZ, and RNEG inputs) directly back to the transmit side (TCLK, TPOS/TNRZ, and TNEG outputs). When this loopback is enabled, the incoming data continues to pass through the receive framer block, but the output data from the transmit formatter is ignored. See [Figure 1-1](#) for a visual description of this loopback. Setting the LLB bit in the [MC2](#) register activates the line loopback.

### 7.5.2 Diagnostic Loopback

The diagnostic loopback sends the outgoing DS3/E3 data directly back to the receive side. When this loopback is enabled, the incoming receive data at RCLK, RPOS, and RNEG is ignored. See [Figure 1-1](#) for a visual description of this loopback. During diagnostic loopback the device can simultaneously generate AIS at the TCLK, TPOS, and TNEG outputs, while regular traffic is looped back to the receiver. This feature keeps the diagnostic signal that is being looped back from disturbing downstream equipment. Setting the DLB bit in the [MC2](#) register activates the diagnostic loopback.

### 7.5.3 Payload Loopback

The payload loopback sends the DS3/E3 payload from the receive framer back to the transmit formatter. When this loopback is enabled, the incoming receive data continues to be present on the RDAT pin, but the transmit data on the TDAT pin is ignored. During payload loopback, the TSOFF and TDEN signals are realigned to the receive frame, and the signals at TOH and TOHEN are active and can still overwrite any bit position. See [Figure 1-1](#) for a visual description of this loopback. During payload loopback TSOFF, TDEN, TOHEN, and TOH are aligned to the ROCLK signal. When PLB and DLB are both set, diagnostic loopback takes precedence. Setting the PLB bit in the [MC2](#) register activates payload loopback.

### 7.5.4 BERT and Loopback Interaction

[Table 7-A](#) describes how the payload bits move through the device with various combinations of BERT modes and loopbacks active. The BERT mode is set in the BM[1:0] bits in the [BCR1](#) register. The BERT is enabled when the BENA bit is set in the [BCR1](#) register. [Table 7-B](#) describes how the overhead bits move through the device with various combinations of BERT modes and loopbacks active.

**Table 7-A. BERT/Loopback Interaction—Payload Bits**

CONFIGURATION BITS				BITS AT PAYLOAD BIT POSITIONS		
DLB	LLB	PLB	BM [1:0]	From RPOS/RNEG To:	From TDAT To:	From BERT To:
0	0	0	0X	BERT and RDAT	Not used	TPOS/TNEG
0	0	0	1X	Not used	BERT and TPOS/TNEG	RDAT
1	0	0	0X	Not used	Not used	TPOS/TNEG, BERT, and RDAT
1	0	0	1X	Not used	BERT and TPOS/TNEG	RDAT
0	1	0	0X	TPOS/TNEG, RDAT, and BERT	Not used	Not used
0	1	0	1X	TPOS/TNEG	BERT	RDAT
0	0	1	00	TPOS/TNEG and RDAT and BERT	Not used	Not used
0	0	1	01	RDAT and BERT	Not used	TPOS/TNEG
0	0	1	1X	TPOS/TNEG	BERT	RDAT

**Table 7-B. BERT/Loopback Interaction—Overhead Bits**

CONFIGURATION BITS				BITS AT OVERHEAD BIT POSITIONS			
DLB	LLB	PLB	BM [1:0]	From RPOS/RNEG To:	From TDAT To:	From Formatter To:	From BERT To:
0	0	0	00	Framer and RDAT	Not used (Note 1)	TPOS/TNEG	Not generated
0	0	0	01	Framer, RDAT and BERT	Not used	Not used	TPOS, TNEG
0	0	0	10	Framer and RDAT	Not used (Note 1)	TPOS/TNEG	Not generated
0	0	0	11	Framer	BERT (Note 2)	TPOS/TNEG	RDAT
1	0	0	00	Not used	Not used (Note 1)	TPOS/TNEG, Framer, and RDAT	Not generated
1	0	0	01	Not used	Not used	Not used	TPOS/TNEG, Framer, BERT, and RDAT
1	0	0	10	Not used	Not used (Note 1)	TPOS/TNEG, Framer, and RDAT	Not generated
1	0	0	11	Not used	BERT (Note 2)	TPOS/TNEG and Framer	RDAT
0	1	0	00	TPOS/TNEG, Framer, and RDAT	Not used	Not used	Not generated
0	1	0	01	TPOS/TNEG, Framer, RDAT, and BERT	Not used	Not used	Not used
0	1	0	10	TPOS/TNEG, Framer, and RDAT	Not used	Not used	Not generated
0	1	0	11	TPOS/TNEG and Framer	BERT (Note 2)	Not used	RDAT
0	0	1	00	Framer and RDAT	Not used (Note 1)	TPOS/TNEG	Not generated
0	0	1	01	Framer, RDAT, and BERT	Not used	Not used	TPOS/TNEG
0	0	1	10	Framer and RDAT	Not used (Note 1)	TPOS/TNEG	Not generated
0	0	1	11	Framer	BERT (Note 2)	TPOS/TNEG	RDAT

**Note 1:** In M23 mode or E3 mode, the transmit formatter sources the C bits from the appropriate bit positions of the TDAT data stream.

**Note 2:** When BM[1:0] = 11, the BERT expects a full-bandwidth (payload plus overhead) pattern to come in on the TDAT pin. In M23 mode or E3 mode with BM[1:0] = 11, the transmit formatter sources the C bits from the appropriate bit positions of the TDAT data stream, even though those bit positions are actually part of the full-bandwidth BERT pattern.

## 7.6 Common and Line Interface Registers

This section describes the registers responsible for top-level configuration, control, and status of each framer, including resets, clocks, pin controls, and line interface functions.

**Table 7-C. Common Line Interface Register Map**

ADDR	REGISTER	BIT 7	BIT 6	BIT 5	BIT 4	BIT 3	BIT 2	BIT 1	BIT 0
00h	<a href="#">ID</a>	<a href="#">ID7</a>	<a href="#">ID6</a>	<a href="#">ID5</a>	<a href="#">ID4</a>	<a href="#">ID3</a>	<a href="#">ID2</a>	<a href="#">ID1</a>	<a href="#">ID0</a>
01h	<a href="#">MC1</a>	LOTMC	ZCSD	BIN	MECU	AECU	TUA1	DISABLE	RST
02h	<a href="#">MC2</a>	OSTCS	TCCLK	N/A	RZSF	N/A	DLB	LLB	PLB
03h	<a href="#">MC3</a>	TDENMS	TSOFC	TOHENI	TOHI	TSOFI	TICLKI	TDATI	TDENI
04h	<a href="#">MC4</a>	RDENMS	ROOFI	RLOSI	RDATA	RSOFI	ROCLKI	RDATI	RDENI
05h	<a href="#">MC5</a>	RNEGI	RPOSI	RCLKI	TNEGH	TPOSH	TNEGI	TPOSI	TCLKI
06h	<a href="#">ISR1</a>	<a href="#">INT8</a>	<a href="#">INT7</a>	<a href="#">INT6</a>	<a href="#">INT5</a>	<a href="#">INT4</a>	<a href="#">INT3</a>	<a href="#">INT2</a>	<a href="#">INT1</a>
07h	<a href="#">ISR2</a>	N/A	N/A	N/A	N/A	<a href="#">INT12</a>	<a href="#">INT11</a>	<a href="#">INT10</a>	<a href="#">INT9</a>
08h	<a href="#">MSR</a>	<a href="#">LORC</a>	<a href="#">LOTCL</a>	<a href="#">T3E3</a>	<a href="#">FEAC</a>	<a href="#">HDLC</a>	<a href="#">BERT</a>	<a href="#">COVF</a>	N/A
09h	<a href="#">MSRL</a>	LORCL	LOTCL	N/A	N/A	N/A	N/A	COVFL	OSTL
0Ah	<a href="#">MSRIE</a>	LORCIE	LOTCLIE	T3E3IE	FEACIE	HDLCIE	BERTIE	COVFIE	OSTIE

Register Name: **ID**  
 Register Description: **ID Register**  
 Register Address: **00h**

Bit #	7	6	5	4	3	2	1	0
Name	<a href="#">ID7</a>	<a href="#">ID6</a>	<a href="#">ID5</a>	<a href="#">ID4</a>	<a href="#">ID3</a>	<a href="#">ID2</a>	<a href="#">ID1</a>	<a href="#">ID0</a>
Default	—	—	—	—	—	—	—	—

*This register is a global resource and is mapped into address 00h in every framer in the device.*

**Bits 0 to 7: Device ID (ID[7:0]).** Read-only. Contact the factory for details on the meaning of the ID bits.

Register Name: **MC1**  
 Register Description: **Master Configuration Register 1**  
 Register Address: **01h**

Bit #	7	6	5	4	3	2	1	0
Name	LOTMC	ZCSD	BIN	MECU	AECU	TUA1	DISABLE	RST
Default	0	0	0	0	0	1	0	0

**Bit 0: Framer Reset (RST).** When this bit is set to logic 1, it forces all of the internal registers in the framer (except this RST bit) to their default state. Only the framer associated with this register is reset. RST must be high for a minimum of 100ns and then returned low. This register bit is logically ORed with the  $\overline{\text{RST}}$  pin.

0 = normal operation

1 = force all internal registers to their default values

**Bit 1: Framer Disable (DISABLE).** Setting this bit disables the framer by stopping all clocks. This reduces the power the framer requires. After the framer is enabled again by clearing this bit, the RST bit must be toggled to initialize the framer again. Toggling the RST bit when DISABLE = 1 automatically enables the framer again.

0 = enable framer

1 = disable framer

**Bit 2: Transmit Unframed All Ones (TUA1).** Enables the transmission of an unframed all-ones pattern on TPOS/TNEG or TNRZ. This pattern is sometimes called physical AIS.

0 = disable transmission of unframed all ones

1 = enable transmission of unframed all ones (reset default value)

**Bit 3: Automatic Error-Counters Update Defeat (AECU).** When this bit is logic 0, the device automatically updates the DS3/E3 performance error counters on an internally created 1-second boundary based on the RCLK or TCLK signal, depending on the OSTCS control bit. The host processor is notified of the update through the setting of the OST status bit in the [MSRL](#) register. In this mode, the host processor has a full 1-second period to retrieve the error count information before it is overwritten with the next update. When this bit is set high, the device disables the automatic 1-second update and enables a manual update mode. In the manual update mode, the device relies on either the RECU hardware input signal or the MECU control bit to update the error counters. The RECU hardware input signal and MECU control bit are logically ORed and therefore a 0-to-1 transition on either initiates an error counter update. After either the RECU signal or MECU bit has toggled, the host processor must wait at least 100ns before reading the error counters to allow the device time to complete the update.

0 = enable the automatic update mode and disable the manual update mode

1 = disable the automatic update mode and enable the manual update mode

**Bit 4: Manual Error-Counter Update (MECU).** A 0-to-1 transition on this bit causes the device to update the performance error counters. This bit is ignored if the AECU control bit is logic 0. This bit must be cleared and set again for a subsequent update. This bit is logically ORed with the RECU input pin.

**Bit 5: DS3/E3 POS/NEG Binary Mode Select (BIN).** Selects the mode of the LIU interface signals.

0 = dual rail mode (data on TPOS/TNEG and RPOS/RNEG)

1 = binary NRZ mode (data on TNRZ and RNRZ with line-code violation pulses on RLCV)

**Bit 6: Zero Code Suppression Disable (ZCSD).** When BIN = 1, zero code suppression is automatically disabled and ZCSD has no effect.

0 = enable the B3ZS/HDB3 encoder and decoder; coding is AMI with zero substitution

1 = disable the B3ZS/HDB3 encoder and decoder; coding is AMI without zero substitution

**Bit 7: Loss-of-Transmit Clock Mux Control (LOTMC).** The device can detect if the TCLK fails to transition. If this bit is logic 0, the device takes no action (other than setting the LOTC status bit) when the TCLK fails to transition. If this bit is logic 1, when TCLK fails to transition the device automatically switches the transmitter to the input receive clock (RCLK) and transmits AIS.

0 = do not switch the transmitter to RCLK if TCLK fails to transition

1 = automatically switch the transmitter to RCLK and transmit AIS if TCLK fails to transition

Register Name: **MC2**  
 Register Description: **Master Configuration Register 2**  
 Register Address: **02h**

Bit #	7	6	5	4	3	2	1	0
Name	OSTCS	TCCLK	N/A	RZSF	N/A	DLB	LLB	PLB
Default	0	0	—	—	—	0	0	0

**Bit 0: Payload Loopback Enable (PLB).** When payload loopback is enabled, the transmit formatter operates from the receive clock (rather than TICLK) and sources DS3/E3 payload bits from the receive data stream rather than from the TDAT input pin. Receive data is still available on the RDAT output pin during payload loopback. See [Figure 1-1](#) for a visual description of this loopback.

- 0 = disable payload loopback
- 1 = enable payload loopback

**Bit 1: Line Loopback Enable (LLB).** Line loopback connects the TPOS, TNEG, and TCLK output pins to the RPOS, RNEG, and RCLK input pins. When line loopback is enabled, the receive framer continues to process the incoming receive data stream and present it on the RDAT pin; the output of the transmit formatter is ignored. Line loopback and diagnostic loopback can be active at the same time to support simultaneous local and far-end loopbacks. See [Figure 1-1](#) for a visual description of this loopback.

- 0 = disable line loopback
- 1 = enable line loopback

**Bit 2: Diagnostic Loopback Enable (DLB).** When diagnostic loopback is enabled, the receive framer sources data from the transmit formatter rather than the RCLK, RPOS, and RNEG input pins. Transmit data is sourced prior to transmit AIS generation, unframed all ones generation, TCLK/TPOS/TNEG pin inversion, and TPOS/TNEG force-high logic. This allows the device to transmit AIS or unframed all ones to the far end while locally looping back the actual transmit data stream, which could be test patterns or other traffic that should not be sent to the far end. See [Figure 1-1](#) for a visual description of this loopback.

- 0 = disable diagnostic loopback
- 1 = enable diagnostic loopback

**Bit 4: Receive Zero Suppression Code Format (RZSF).** When RZSF is set to logic 0, the B3ZS/HDB3 decoder declares a B3ZS codeword when it sees a zero followed by a BPV that has the opposite polarity as the previous BPV, and an HDB3 codeword when it sees two zeros followed by a BPV that has the opposite polarity as the previous BPV. When RZSF is set to logic 1, the polarity of the previous BPV is not considered, and the decoder declares a B3ZS codeword when it sees a zero followed by a BPV and an HDB3 codeword when it sees two zeros followed by a BPV.

**Bit 6: Transmit Constant Clock Select (TCCLK).** When TCCLK is set to logic 1, the device outputs a constant transmit clock on the TDEN/TGCLK pin instead of a data enable or gapped clock. This bit has precedence over the TDENMS bit in register [MC3](#). The pin can still be inverted by [MC3:TDENI](#).

- 0 = the function of the TDEN/TGCLK pin is controlled by TDENMS control bit
- 1 = the TDEN/TGCLK pin is a constant transmit clock output

**Bit 7: One-Second Timer Clock Select (OSTCS).** This control bit selects the clock source for the internal one-second timer.

- 0 = use RCLK
- 1 = use TICLK



Register Name: **MC3**  
 Register Description: **Master Configuration Register 3**  
 Register Address: **03h**

Bit #	7	6	5	4	3	2	1	0
Name	TDENMS	TSOFC	TOHENI	TOHI	TSOFI	TICLKI	TDATI	TDENI
Default	0	0	0	0	0	0	0	0

**Bit 0: TDEN Invert Enable (TDENI)**

0 = do not invert the TDEN/TGCLK signal (normal mode)  
 1 = invert the TDEN/TGCLK signal (inverted mode)

**Bit 1: TDAT Invert Enable (TDATI)**

0 = do not invert the TDAT signal (normal mode)  
 1 = invert the TDAT signal (inverted mode)

**Bit 2: TICLK Invert Enable (TICLKI)**

0 = do not invert the TICLK signal (normal mode)  
 1 = invert the TICLK signal (inverted mode)

**Bit 3: TSOF Invert Enable (TSOFI)**

0 = do not invert the TSOF signal (normal mode)  
 1 = invert the TSOF signal (inverted mode)

**Bit 4: TOH Invert Enable (TOHI)**

0 = do not invert the TOH signal (normal mode)  
 1 = invert the TOH signal (inverted mode)

**Bit 5: TOHEN Invert Enable (TOHENI)**

0 = do not invert the TOHEN signal (normal mode)  
 1 = invert the TOHEN signal (inverted mode)

**Bit 6: Transmit Start-of-Frame I/O Control (TSOFC).** When this bit is logic 1, the TSOF pin is an output and pulses for the last TICLK cycle of each frame. When this bit is 0, the TSOF pin is an input, and the device uses it to determine the frame boundaries. See [Figure 5-1](#) for functional timing information.

0 = TSOF is an input (reset default as input)  
 1 = TSOF is an output

**Bit 7: Transmit Data-Enable Mode Select (TDENMS).** When this bit is logic 0, the TDEN/TGCLK output has the TDEN (data enable) function. TDEN asserts during payload bit times and de-asserts during overhead bit times. When this bit is logic 1, TDEN/TGCLK has the TGCLK (gapped clock) function. TGCLK pulses during payload bit times and is suppressed during overhead bit times. The TCCLK control bit in the [MC2](#) register has precedence over this control bit. See [Figure 5-1](#) for functional timing information.

0 = TDEN (data enable) mode  
 1 = TGCLK (gapped clock) mode

Register Name: **MC4**  
 Register Description: **Master Configuration Register 4**  
 Register Address: **04h**

Bit #	7	6	5	4	3	2	1	0
Name	RDENMS	ROOFI	RLOSI	RDATH	RSOFI	ROCLKI	RDATI	RDENI
Default	0	0	0	1	0	0	0	0

**Bit 0: RDEN Invert Enable (RDENI)**

0 = do not invert the RDEN signal (normal mode)  
 1 = invert the RDEN signal (inverted mode)

**Bit 1: RDAT Invert Enable (RDATI)**

0 = do not invert the RDAT signal (normal mode)  
 1 = invert the RDAT signal (inverted mode)

**Bit 2: ROCLK Invert Enable (ROCLKI)**

0 = do not invert the ROCLK signal (normal mode)  
 1 = invert the ROCLK signal (inverted mode)

**Bit 3: RSOF Invert Enable (RSOFI)**

0 = do not invert the RSOF signal (normal mode)  
 1 = invert the RSOF signal (inverted mode)

**Bit 4: RDAT Force High (RDATH).** This bit is set to logic 1 at reset, which puts an all-ones signal on the RDAT pin. This pin should be cleared once the device has framed to a valid signal. The RDAT pin can be forced low by setting both the RDATH and RDATI control bits.

0 = do not force RDAT high (normal mode)  
 1 = force RDAT high (default reset mode)

**Bit 5: RLOS Invert Enable (RLOSI)**

0 = do not invert the RLOS signal (normal mode)  
 1 = invert the RLOS signal (inverted mode)

**Bit 6: ROOF Invert Enable (ROOFI)**

0 = do not invert the ROOF signal (normal mode)  
 1 = invert the ROOF signal (inverted mode)

**Bit 7: Receive Data-Enable Mode Select (RDENMS).** When this bit is logic 0, the RDEN/RGCLK output has the RDEN (data enable) function. RDEN asserts during payload bit times and de-asserts during overhead bit times. When this bit is logic 1, RDEN/RGCLK has the RGCLK (gapped clock) function. RGCLK pulses during payload bit times and is suppressed during overhead bit times. See [Figure 5-2](#) for timing information.

0 = RDEN (data enable) mode  
 1 = RGCLK (gapped clock) mode

Register Name: **MC5**  
 Register Description: **Master Configuration Register 5**  
 Register Address: **05h**

Bit #	7	6	5	4	3	2	1	0
Name	RNEGI	RPOSI	RCLKI	TNEGH	TPOSH	TNEGI	TPOSI	TCLKI
Default	0	0	0	0	0	0	0	0

**Bit 0: TCLK Invert Enable (TCLKI)**

- 0 = do not invert the TCLK signal (normal mode)
- 1 = invert the TCLK signal (inverted mode)

**Bit 1: TPOS/TNRZ Invert Enable (TPOSI)**

- 0 = do not invert the TPOS/TNRZ signal (normal mode)
- 1 = invert the TPOS/TNRZ signal (inverted mode)

**Bit 2: TNEG Invert Enable (TNEGI)**

- 0 = do not invert the TNEG signal (normal mode)
- 1 = invert the TNEG signal (inverted mode)

**Bit 3: TPOS/TNRZ Force-High Enable (TPOSH).** The TPOS/TNRZ pin can be forced low by setting both the TPOSH and TPOSI control bits.

- 0 = allow normal transmit data to appear at the TPOS/TNRZ pin (normal mode)
- 1 = force the TPOS/TNRZ signal high (force high mode, can be inverted)

**Bit 4: TNEG Force-High Enable (TNEGH).** The TNEG pin can be forced low by setting both the TNEGH and TNEGI control bits.

- 0 = allow normal transmit data to appear at the TNEG pin (normal mode)
- 1 = force the TNEG signal high (force high mode, can be inverted)

**Bit 5: RCLK Invert Enable (RCLKI)**

- 0 = do not invert the RCLK signal (normal mode)
- 1 = invert the RCLK signal (inverted mode)

**Bit 6: RPOS/RNRZ Invert Enable (RPOSI)**

- 0 = do not invert the RPOS/RNRZ signal (normal mode)
- 1 = invert the RPOS/RNRZ signal (inverted mode)

**Bit 7: RNEG/RLCV Invert Enable (RNEGI)**

- 0 = do not invert the RNEG/RLCV signal (normal mode)
- 1 = invert the RNEG/RLCV signal (inverted mode)

Register Name: **ISR1**  
 Register Description: **Interrupt Status Register 1**  
 Register Address: **06h**

Bit #	7	6	5	4	3	2	1	0
Name	<u>INT8</u>	<u>INT7</u>	<u>INT6</u>	<u>INT5</u>	<u>INT4</u>	<u>INT3</u>	<u>INT2</u>	<u>INT1</u>
Default	—	—	—	—	—	—	—	—

*This register is a global resource and is mapped into address 06h in every framer in the device. In both interrupt-based and polling-based device servicing strategies, the host processor should read this register and the ISR2 register first to determine which framers require servicing.*

**Bit 0: Interrupt 1 (INT1).** This bit is set when framer 1 is driving the  $\overline{\text{INT}}$  pin.

**Bit 1: Interrupt 2 (INT2).** This bit is set when framer 2 is driving the  $\overline{\text{INT}}$  pin.

**Bit 2: Interrupt 3 (INT3).** This bit is set when framer 3 is driving the  $\overline{\text{INT}}$  pin.

**Bit 3: Interrupt 4 (INT4).** This bit is set when framer 4 is driving the  $\overline{\text{INT}}$  pin.

**Bit 4: Interrupt 4 (INT5).** This bit is set when framer 5 is driving the  $\overline{\text{INT}}$  pin.

**Bit 5: Interrupt 4 (INT6).** This bit is set when framer 6 is driving the  $\overline{\text{INT}}$  pin.

**Bit 6: Interrupt 4 (INT7).** This bit is set when framer 7 is driving the  $\overline{\text{INT}}$  pin.

**Bit 7: Interrupt 4 (INT8).** This bit is set when framer 8 is driving the  $\overline{\text{INT}}$  pin.

Register Name: **ISR2**  
 Register Description: **Interrupt Status Register 2**  
 Register Address: **07h**

Bit #	7	6	5	4	3	2	1	0
Name	N/A	N/A	N/A	N/A	<u>INT12</u>	<u>INT11</u>	<u>INT10</u>	<u>INT9</u>
Default	—	—	—	—	—	—	—	—

*This register is a global resource and is mapped into address 07h in every framer in the device. In both interrupt-based and polling-based device servicing strategies, the host processor should read this register and the ISR1 register first to determine which framers require servicing.*

**Bit 0: Interrupt 9 (INT9).** This bit is set when framer 9 is driving the  $\overline{\text{INT}}$  pin.

**Bit 1: Interrupt 10 (INT10).** This bit is set when framer 10 is driving the  $\overline{\text{INT}}$  pin.

**Bit 2: Interrupt 11 (INT11).** This bit is set when framer 11 is driving the  $\overline{\text{INT}}$  pin.

**Bit 3: Interrupt 12 (INT12).** This bit is set when framer 12 is driving the  $\overline{\text{INT}}$  pin.

### 7.6.1 Master Status Register (MSR)

The master status register (MSR) is a special status register that helps the host processor quickly locate changes in device status. Each major block in the framer has a status bit in the MSR. When an alarm or event occurs in one of these blocks, the device can be configured to set the appropriate bit in the MSR. The latched status bits in the [MSRL](#) can also cause a hardware interrupt to occur. In both interrupt-based and polling-based device servicing strategies, the host processor should read the [ISR1](#) register to determine which framers need service and then read the [MSRL](#) register of each framer that needs service to determine which blocks within the framer need service.

Register Name: **MSR**  
 Register Description: **Master Status Register**  
 Register Address: **08h**

Bit #	7	6	5	4	3	2	1	0
Name	<a href="#">LORC</a>	<a href="#">LOTC</a>	<a href="#">T3E3</a>	<a href="#">FEAC</a>	<a href="#">HDLC</a>	<a href="#">BERT</a>	<a href="#">COVF</a>	N/A
Default	—	—	—	—	—	—	—	—

**Bit 1: Counter Overflow Event (COVF).** This real-time status bit is set to 1 if any of the error counters saturate (the error counters saturate when full). This bit is cleared when the error counters are cleared. The error counters are discussed in Section [7.8](#).

**Bit 2: Change in BERT Status (BERT).** This real-time status bit is set when any of the bits in the [BSRL](#) register are set and the corresponding bits in the [BSRIE](#) interrupt-enable register are set. This bit is cleared when the latched status bits in the [BSRL](#) register are cleared or the interrupt-enable bits in the [BSRIE](#) register are cleared. The setting of this status bit can cause a hardware interrupt to occur if the BERTIE bit in the [MSRIE](#) register is set to a 1. The interrupt is cleared when this bit is cleared or the interrupt-enable bit in the [MSRIE](#) register is cleared.

**Bit 3: Change in HDLC Status (HDLC).** This real-time status bit is set when any of the bits in the [HSRL](#) register are set and the corresponding bits in the [HSRIE](#) interrupt-enable register are set. This bit is cleared when the latched status bits in the [HSRL](#) register are cleared or the interrupt-enable bits in the [HSRIE](#) register are cleared. The setting of this status bit can cause a hardware interrupt to occur if the HDLCIE bit in the [MSRIE](#) register is set to a 1. The interrupt is cleared when this bit is cleared or the interrupt-enable bit in the [MSRIE](#) register is cleared.

**Bit 4: Change in FEAC Status (FEAC).** This real-time status bit is set when any of the bits in the [FSRL](#) register are set and the corresponding bits in the [FSRIE](#) interrupt-enable register are set. This bit is cleared when the latched status bits in the [FSRL](#) register are cleared or the interrupt-enable bits in the [FSRIE](#) register are cleared. The setting of this status bit can cause a hardware interrupt to occur if the FEACIE bit in the [MSRIE](#) register is set to a 1. The interrupt is cleared when this bit is cleared or the interrupt-enable bit in the [MSRIE](#) register is cleared.

**Bit 5: Change in DS3/E3 Framer Status (T3E3).** This real-time status bit is set when any of the bits in the [T3E3SRL](#) register are set and the corresponding bits in the [T3E3SRIE](#) interrupt-enable register are set. This bit is cleared when the latched status bits in the [T3E3SRL](#) register are cleared or the interrupt-enable bits in the [T3E3SRIE](#) register are cleared. The setting of this status bit can cause a hardware interrupt to occur if the T3E3IE bit in the [MSRIE](#) register is set to 1. The interrupt is cleared when this bit is cleared or the interrupt-enable bit in the [MSRIE](#) register is cleared.

**Bit 6: Loss-of-Transmit Clock Detected (LOTC).** This real-time status bit is set when the device detects that the TCLK input pin has not toggled for between 9 and 21 clock periods. This bit is cleared when a clock is detected at the TCLK input. The system clock (SCLK) is used to check for the presence of the TCLK. On reset the LOTC status bit is set for a few clock cycles and then cleared if TCLK is present.

**Bit 7: Loss-of-Receive Clock Detected (LORC).** This real-time status bit is set when the device detects that the RCLK input pin has not toggled for between 9 and 21 clock periods. This bit is cleared when a clock is detected at the RCLK input. The system clock (SCLK) checks for the presence of the RCLK. On reset the LORC status bit is set for a few clock cycles and then cleared if RCLK is present.

Register Name: **MSRL**  
 Register Description: **Master Status Register Latched**  
 Register Address: **09h**

Bit #	7	6	5	4	3	2	1	0
Name	LORCL	LOTCL	N/A	N/A	N/A	N/A	COVFL	OSTL
Default	—	—	—	—	—	—	—	—

**Note:** See [Figure 7-4](#) for details on the interrupt logic for the status bits in the MSRL register.

**Bit 0: One-Second Timer Latched (OSTL).** This latched status bit is set to 1 on each 1-second boundary, as timed by the device. The device chooses an arbitrary 1-second boundary that is timed from either the RCLK signal or the TCLK signal depending on the setting of the OSTCS bit in [MC2](#). OSTL is cleared when the host processor writes a 1 to it and is not set again until another 1-second boundary has occurred. When OSTL is set, it can cause a hardware interrupt to occur if the OSTIE bit in the [MSRIE](#) register is set to 1. The interrupt is cleared when this bit is cleared or the interrupt-enable bit is cleared. This bit can be used to determine when to read the error counters, if the counters are automatically updated by the 1-second timer.

**Bit 1: Counter Overflow Event Latched (COVFL).** This latched status bit is set to 1 when the COVF status bit in the [MSR](#) register goes high. COVFL is cleared when the host processor writes a 1 to it and is not set again until COVF goes high again. When COVFL is set, it can cause a hardware interrupt to occur if the COVFIE bit in the [MSRIE](#) register is set to 1. The interrupt is cleared when this bit is cleared or the interrupt-enable bit is cleared. This bit can be used to determine when a counter overflow event occurs.

**Bit 6: Loss-of-Transmit Clock Latched (LOTCL).** This latched status bit is set to 1 when the LOTC status bit in the [MSR](#) register goes high. LOTCL is cleared when the host processor writes a 1 to it and is not set again until LOTC goes high again. When LOTCL is set, it can cause a hardware interrupt to occur if the LOTCIE bit in the [MSRIE](#) register is set to 1. The interrupt is cleared when this bit is cleared or the interrupt-enable bit is cleared. This bit can be used to determine when a loss of transmit clock event occurs.

**Bit 7: Loss-of-Receive Clock Latched (LORCL).** This latched status bit is set to 1 when the LORC status bit in the [MSR](#) register goes high. LORCL is cleared when the host processor writes a 1 to it and is not set again until LORC goes high again. When LORCL is set, it can cause a hardware interrupt to occur if the LORCIE bit in the [MSRIE](#) register is set to 1. The interrupt is cleared when this bit is cleared or the interrupt-enable bit is cleared. This bit can be used to determine when a loss of receive clock event occurs.

Register Name: **MSRIE**  
 Register Description: **Master Status Register Interrupt Enable**  
 Register Address: **0Ah**

Bit #	7	6	5	4	3	2	1	0
Name	LORCIE	LOTClE	T3E3IE	FEACIE	HDLCIE	BERTIE	COVFIE	OSTIE
Default	0	0	0	0	0	0	0	0

**Bit 0: One-Second Timer Interrupt Enable (OSTIE).** This bit enables an interrupt if the OSTL bit in the [MSRL](#) register is set.

- 0 = interrupt disabled
- 1 = interrupt enabled

**Bit 1: Counter Overflow Event Interrupt Enable (COVFIE).** This bit enables an interrupt if the COVFL bit in the [MSRL](#) register is set.

- 0 = interrupt disabled
- 1 = interrupt enabled

**Bit 2: Change in BERT Status Interrupt Enable (BERTIE).** This bit enables an interrupt if the BERT bit in the [MSR](#) register is set.

- 0 = interrupt disabled
- 1 = interrupt enabled

**Bit 3: Change in HDLC Status Interrupt Enable (HDLCIE).** This bit enables an interrupt if the HDLC bit in the [MSR](#) register is set.

- 0 = interrupt disabled
- 1 = interrupt enabled

**Bit 4: Change in FEAC Status Interrupt Enable (FEACIE).** This bit enables an interrupt if the FEAC bit in the [MSR](#) register is set.

- 0 = interrupt disabled
- 1 = interrupt enabled

**Bit 5: Change in DS3/E3 Framer Status Interrupt Enable (T3E3IE).** This bit enables an interrupt if the T3E3 bit in the [MSR](#) register is set.

- 0 = interrupt disabled
- 1 = interrupt enabled

**Bit 6: Loss-of-Transmit Clock Interrupt Enable (LOTClE).** This bit enables an interrupt if the LOTCL bit in the [MSRL](#) register is set.

- 0 = interrupt disabled
- 1 = interrupt enabled

**Bit 7: Loss-of-Receive Clock Interrupt Enable (LORClE).** This bit enables an interrupt if the LORCL bit in the [MSRL](#) register is set.

- 0 = interrupt disabled
- 1 = interrupt enabled

**Figure 7-4. MSR Status Bit Interrupt Signal Flow**

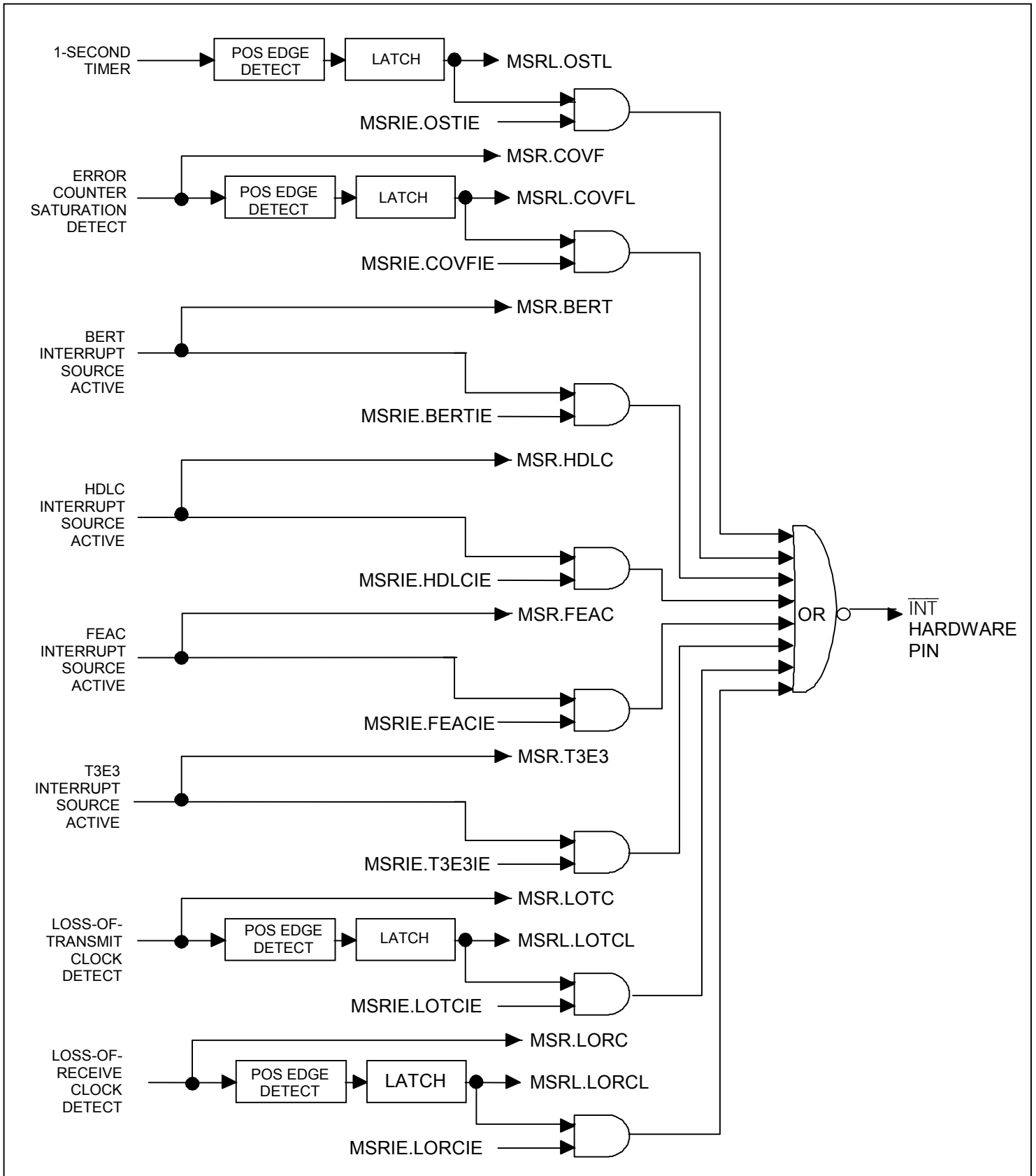



## 7.7 DS3/E3 Framer

**Table 7-D. DS3/E3 Framer Register Map**

ADDR	REGISTER	BIT 7	BIT 6	BIT 5	BIT 4	BIT 3	BIT 2	BIT 1	BIT 0
10	<a href="#">T3E3CR1</a>	E3SnC1	E3SnC0	T3IDLE	TRAI	TAIS	TPT	CBEN	DS3M
11	<a href="#">T3E3CR2</a>	FRESYNC	N/A	TFEBE	AFEDED	ECC	FECC1	FECC0	E3CVE
12	<a href="#">T3E3EIC</a>	MEIMS	FBEIC1	FBEIC0	FBEI	T3CPBEI	T3PBEI	EXZI	BPVI
18	<a href="#">T3E3SR</a>	N/A	N/A	<u>SEF</u>	<u>T3IDLE</u>	<u>RAI</u>	<u>AIS</u>	<u>OOF</u>	<u>LOS</u>
19	<a href="#">T3E3SRL</a>	COFAL	N/A	SEFL	T3IDLEL	RAIL	AISL	OOFL	LOSL
1A	<a href="#">T3E3SRIE</a>	COFAIE	N/A	SEFIE	T3IDLEIE	RAIIE	AISIE	OOFIE	LOSIE
1B	<a href="#">T3E3IR</a>	<u>RUA1</u>	<u>T3AIC</u>	<u>E3Sn</u>	N/A	EXZL	MBEL	FBEL	ZSCDL
20	<a href="#">BPVCR1</a>	<u>BPV7</u>	<u>BPV6</u>	<u>BPV5</u>	<u>BPV4</u>	<u>BPV3</u>	<u>BPV2</u>	<u>BPV1</u>	<u>BPV0</u>
21	<a href="#">BPVCR2</a>	<u>BPV15</u>	<u>BPV14</u>	<u>BPV13</u>	<u>BPV12</u>	<u>BPV11</u>	<u>BPV10</u>	<u>BPV9</u>	<u>BPV8</u>
22	<a href="#">EXZCR1</a>	<u>EXZ7</u>	<u>EXZ6</u>	<u>EXZ5</u>	<u>EXZ4</u>	<u>EXZ3</u>	<u>EXZ2</u>	<u>EXZ1</u>	<u>EXZ0</u>
23	<a href="#">EXZCR2</a>	<u>EXZ15</u>	<u>EXZ14</u>	<u>EXZ13</u>	<u>EXZ12</u>	<u>EXZ11</u>	<u>EXZ10</u>	<u>EXZ9</u>	<u>EXZ8</u>
24	<a href="#">FECR1</a>	<u>FE7</u>	<u>FE6</u>	<u>FE5</u>	<u>FE4</u>	<u>FE3</u>	<u>FE2</u>	<u>FE1</u>	<u>FE0</u>
25	<a href="#">FECR2</a>	<u>FE15</u>	<u>FE14</u>	<u>FE13</u>	<u>FE12</u>	<u>FE11</u>	<u>FE10</u>	<u>FE9</u>	<u>FE8</u>
26	<a href="#">PCR1</a>	<u>PE7</u>	<u>PE6</u>	<u>PE5</u>	<u>PE4</u>	<u>PE3</u>	<u>PE2</u>	<u>PE1</u>	<u>PE0</u>
27	<a href="#">PCR2</a>	<u>PE15</u>	<u>PE14</u>	<u>PE13</u>	<u>PE12</u>	<u>PE11</u>	<u>PE10</u>	<u>PE9</u>	<u>PE8</u>
28	<a href="#">CPCR1</a>	<u>CPE7</u>	<u>CPE6</u>	<u>CPE5</u>	<u>CPE4</u>	<u>CPE3</u>	<u>CPE2</u>	<u>CPE1</u>	<u>CPE0</u>
29	<a href="#">CPCR2</a>	<u>CPE15</u>	<u>CPE14</u>	<u>CPE13</u>	<u>CPE12</u>	<u>CPE11</u>	<u>CPE10</u>	<u>CPE9</u>	<u>CPE8</u>
2A	<a href="#">FEBE3R1</a>	<u>FEBE7</u>	<u>FEBE6</u>	<u>FEBE5</u>	<u>FEBE4</u>	<u>FEBE3</u>	<u>FEBE2</u>	<u>FEBE1</u>	<u>FEBE0</u>
2B	<a href="#">FEBE3R2</a>	<u>FEBE15</u>	<u>FEBE14</u>	<u>FEBE13</u>	<u>FEBE12</u>	<u>FEBE11</u>	<u>FEBE10</u>	<u>FEBE9</u>	<u>FEBE8</u>

Register Name: **T3E3CR1**  
 Register Description: **T3/E3 Control Register**  
 Register Address: **10h**

Bit #	7	6	5	4	3	2	1	0
Name	E3SnC1	E3SnC0	T3IDLE	TRAI	TAIS	TPT	CBEN	DS3M
Default	0	0	0	0	0	0	0	0

**Bit 0: DS3 Mode Select (DS3M).** Selects DS3 or E3 operation. It must be set immediately after reset to select DS3 mode.

- 0 = E3 mode
- 1 = DS3 mode

**Bit 1: C-Bit Parity Mode Enable (CBEN).** This bit is only active when the framer is in DS3 mode. When this bit is logic 0, C-Bit Parity is defeated and the C bits are sourced from the TDAT input pin.

- 0 = disable C-Bit Parity mode (also known as the M23 mode)
- 1 = enable C-Bit Parity mode

**Bit 2: DS3/E3 Transmit Pass-Through Enable (TPT).** When this bit is set to logic 1, the transmit formatter sources data from the TDAT input on every TCLK cycle and does not insert framing overhead into the transmit data stream. In this mode the TDEN/TGCLK output still marks where the payload bits would be if TPT were not enabled, and the TSOFF output still marks the start of a frame. When in this mode, the BERT does not function in payload-only mode; entire-frame mode should be used instead.

- 0 = configure the formatter to insert framing overhead bits
- 1 = configure the formatter to pass through TDAT data without inserting framing overhead bits

**Bit 3: DS3/E3 Transmit Alarm Indication Signal (TAIS).** When this bit is logic 1 in DS3 mode, the transmitter generates DS3 AIS, which is a properly F-bit and M-bit framed 1010... data pattern with both X bits set to 1, all C bits set to 0, and the proper P bits. When this bit is logic 1 in E3 mode, the transmitter generates an unframed all-ones pattern. When this bit is logic 0, normal data is transmitted.

0 = do not transmit AIS

1 = transmit AIS

**Bit 4: DS3/E3 Transmit Remote Alarm Indication (TRAI).** When this bit is logic 1 in DS3 mode, both X bits of each DS3 frame are set to logic 0. When this bit is logic 1 in E3 mode, the RAI bit (bit 11 of each E3 frame) is set to logic 1. When this bit is logic 0 in DS3 mode, both X bits are set to logic 1. When this bit is logic 0 in E3 mode, the RAI bit is set to logic 0.

0 = do not transmit RAI

1 = transmit RAI

**Bit 5: Transmit DS3 Idle Signal Enable (T3IDLE).** When this bit is logic 1 in DS3 mode, the transmitter generates the DS3 idle signal instead of the normal transmit data. The DS3 idle signal is defined as a normally DS3 framed pattern (i.e., with the proper F bits and M bits along with the proper P bits) where the information bit fields are completely filled with a data pattern of 1100..., the C bits in Subframe 3 are set to logic 0, and both X bits are set to logic 1. In C-Bit Parity mode, the PMDL and FEAC channels are still enabled. This bit is ignored in the E3 mode.

0 = do not transmit DS3 idle signal

1 = transmit DS3 idle signal

**Bits 6, 7: E3 National Bit Control (E3SnC[1:0]).** These bits determine the source of the E3 National bit (Sn). On the receive side, the Sn bit is always routed to the [T3E3IR](#) register as well as the HDLC controller and the FEAC controller. These bits are ignored in DS3 mode.

E3SnC1	E3SnC0	SOURCE OF THE E3 NATIONAL BIT (Sn)
0	0	Force the Sn bit to logic 1
0	1	Source the Sn bit from the HDLC controller
1	0	Source the Sn bit from the FEAC controller
1	1	Force the Sn bit to logic 0

Register Name: **T3E3CR2**  
 Register Description: **DS3/E3 Control Register**  
 Register Address: **11h**

Bit #	7	6	5	4	3	2	1	0
Name	FRESYNC	N/A	TFEBE	AFEBED	ECC	FECC1	FECC0	E3CVE
Default	0	—	0	0	0	0	0	0

**Bit 0: E3 Code Violation Enable (E3CVE).** This bit is ignored in the DS3 mode. In E3 mode, this bit is used to configure the bipolar violation count register ([BPVCR1](#)) to count either bipolar violations (BPV) or code violations (CV). A BPV is defined as consecutive pulses (or marks) of the same polarity that are not part of an HDB3 codeword. A CV is defined in ITU O.161 as consecutive BPVs of the same polarity.

- 0 = count BPVs
- 1 = count CVs

#### Bits 1, 2: Frame Error-Counting Control (FECC[1:0])

FECC[1:0]	FRAME ERROR-COUNT REGISTER ( <a href="#">FECR1</a> ) CONFIGURATION
00	DS3 Mode: Count OOF occurrences E3 Mode: Count OOF occurrences
01	DS3 Mode: Count both F-bit and M-bit errors E3 Mode: Count bit errors in the FAS word
10	DS3 Mode: Count only F-bit errors E3 Mode: Count word errors in the FAS word
11	DS3 Mode: Count only M-bit errors E3 Mode: Illegal state

**Bit 3: Error-Counting Control (ECC).** This bit is used to control whether the framer increments certain error counters during OOF conditions. It only affects the error counters that deal with framing overhead:

- Frame Error-Count Register ([FECR1](#)) (when it is configured to count frame errors, not OOFs)
- DS3 P-Bit Parity Error-Count Register ([PCR1](#))
- DS3 CP-Bit Parity Error-Count Register ([CPCR1](#))
- DS3 Far-End Block Error-Count Register ([FEBECCR1](#))

When this bit is logic 0, these error counters are not allowed to increment during OOF conditions. When this bit is logic 1, these error counters are allowed to increment during OOF conditions.

- 0 = do not allow the FECR/PCR/CPCR/FEBECCR error counters to increment during OOF
- 1 = allow the FECR/PCR/CPCR/FEBECCR error counters to increment during OOF

**Bit 4: Automatic FEBE Defeat (AFEBED).** This bit is ignored in E3 mode and in M23 DS3 mode. When this bit is low, the framer automatically inserts FEBE codes into the transmit data stream by setting all three C bits in M-subframe 4 to logic 0. A FEBE condition occurs when any received M bits or F bits are in error, or when the received CP bits indicate a parity error or when the receiver is in the OOF condition.

- 0 = automatically insert FEBE codes in the transmit data stream based on detected errors
- 1 = use the TFEBE control to determine the state of the FEBE codes

**Bit 5: Transmit FEBE Setting (TFEBE).** This bit is only active when AFEBED is logic 1. When this bit is logic 0, the formatter forces the FEBE code to 111. When this bit is set logic 1, the formatter forces the FEBE code to 000.

- 0 = force FEBE to 111 (null state)
- 1 = force FEBE to 000 (active state)

**Bit 7: Force Receive Framer Resynchronization (FRESYNC).** A 0-to-1 transition on this bit causes the receive framer to resynchronize. This bit must be cleared and set again for a subsequent resynchronization to occur.

Register Name: **T3E3EIC**  
 Register Description: **DS3/E3 Error Insert Control Register**  
 Register Address: **12h**

Bit #	7	6	5	4	3	2	1	0
Name	MEIMS	FBEIC1	FBEIC0	FBEI	T3CPBEI	T3PBEI	EXZI	BPVI
Default	0	0	0	0	0	0	0	0

**Bit 0: Bipolar Violation Insert (BPVI).** A 0-to-1 transition on this bit causes a single BPV to be inserted into the transmit data stream during the next occurrence of three consecutive 1s. This bit must be cleared and set again for a subsequent BPV to be inserted. Toggling this bit has no effect when the LIU interface is in the binary mode. In the manual error insert mode (MEIMS = 1), errors are inserted on each toggle of the TMEI input signal as long as this bit is logic 1. When this bit is logic 0, no BPVs are inserted.

**Bit 1: Excessive Zero Insert (EXZI).** A 0-to-1 transition on this bit causes a single EXZ event to be inserted into the transmit data stream. An EXZ event is defined as three or more consecutive 0s in the DS3 mode and four or more consecutive 0s in the E3 mode. After this bit has been toggled from logic 0 to logic 1, the formatter suppresses the next possible B3ZS/HDB3 codeword substitution to create the EXZ event. This bit must be cleared and set again for a subsequent EXZ event to be inserted. Toggling this bit has no effect when the LIU interface is in the binary mode. In the manual error insert mode (MEIMS = 1), errors are inserted on each toggle of the TMEI input signal as long as this bit is logic 1. When this bit is logic 0, no EXZ events are inserted.

**Bit 2: DS3 P-Bit Parity Error Insert (T3PBEI).** A 0-to-1 transition on this bit causes a single DS3 P-bit parity error event to be inserted into the transmit data stream. A DS3 P-bit parity error is defined as inverting both P bits in a DS3 frame. Once this bit has been toggled from logic 0 to logic 1, the formatter flips both P bits in the next DS3 frame. This bit must be cleared and set again for a subsequent error to be inserted. Toggling this bit has no effect when the framer is operated in the E3 mode. In the manual error insert mode (MEIMS = 1), errors are inserted on each toggle of the TMEI input signal as long as this bit is logic 1. When this bit is logic 0, no P-bit parity errors are inserted.

**Bit 3: DS3 C-Bit Parity Error Insert (T3CPBEI).** A 0-to-1 transition on this bit causes a single DS3 CP-bit parity error event to be inserted into the transmit data stream. A DS3 CP-bit parity error is defined as inverting the proper polarity of all three CP bits in a DS3 frame. Once this bit has been toggled from logic 0 to logic 1, the framer flips all three CP bits in the next DS3 frame. This bit must be cleared and set again for a subsequent error to be inserted. Toggling this bit has no effect when the framer is not operated in C-Bit Parity mode or when the framer is operated in the E3 mode. In the manual error insert mode (MEIMS = 1), errors are inserted on each toggle of the TMEI input signal as long as this bit is logic 1. When this bit is logic 0, no CP-bit parity errors are inserted.

**Bit 4: Frame Bit-Error Insert (FBEI).** A 0-to-1 transition on this bit causes the transmit framer to generate framing bit errors. The type of framing bit error to be inserted is controlled by the FBEIC[1:0] bits. Once this bit has been toggled from logic 0 to logic 1, the framer inserts framing bit errors in the next possible frame. This bit must be cleared and set again for a subsequent error to be inserted. In the manual error insert mode (MEIMS = 1), errors are inserted on each toggle of the TMEI input signal as long as this bit is logic 1. When this bit is logic 0, no frame bit errors are inserted.

#### Bits 5, 6: Frame Bit-Error Insert Control Bits 0 and 1 (FBEIC[1:0])

FBEIC[1:0]	TYPE OF FRAMING BIT ERROR INSERTED
00	<b>DS3 Mode:</b> A single F-bit error <b>E3 Mode:</b> A single FAS word of 1111 <u>1</u> 10000 is generated instead of the normal FAS word, which is 1111 <u>0</u> 10000 (i.e., only 1 bit inverted)
01	<b>DS3 Mode:</b> A single M-bit error <b>E3 Mode:</b> A single FAS word of 0000101111 is generated instead of the normal FAS word, which is 1111010000 (i.e., all FAS bits are inverted)
10	<b>DS3 Mode:</b> Four consecutive F-bit errors (causes the far end to lose synchronization) <b>E3 Mode:</b> Four consecutive FAS words of 1111 <u>1</u> 10000 are generated instead of the normal FAS word, which is 1111 <u>0</u> 10000 (i.e., only 1 bit inverted; causes the far end to lose synchronization)
11	<b>DS3 Mode:</b> Three consecutive M-bit errors (causes the far end to lose synchronization) <b>E3 Mode:</b> Four consecutive FAS words of 0000101111 are generated instead of the normal FAS word, which is 1111010000 (i.e., all FAS bits are inverted; causes the far end to lose synchronization)

**Bit 7: Manual Error-Insert Mode Select (MEIMS).** When this bit is logic 0, the framer inserts errors on each 0-to-1 transition of the BPVI, EXZI, T3PBEI, T3CPBEI, or FBEI control bits. When this bit is logic 1, the framer inserts errors on each 0-to-1 transition of the TMEI input signal. The appropriate BPVI, EXZI, T3PBEI, T3CPBEI, or FBEI control bit must be set to 1 for this to occur. If all of the BPVI, EXZI, T3PBEI, T3CPBEI, and FBEI control bits are set to 0, no errors are inserted.

0 = use 0-to-1 transition on the BPVI, EXZI, T3PBEI, T3CPBEI, or FBEI control bits to insert errors

1 = use 0-to-1 transition on the TMEI input signal to insert errors

Register Name: **T3E3SR**  
 Register Description: **DS3/E3 Status Register**  
 Register Address: **18h**

Bit #	7	6	5	4	3	2	1	0
Name	N/A	N/A	SEF	T3IDLE	RAI	AIS	OOF	LOS
Default	—	—	—	—	—	—	—	—

**Bit 0: Loss-of-Signal Occurrence (LOS).** This real-time status bit is set when the framer detects loss-of-signal and cleared when the LOS condition terminates. The LOS alarm criteria are described in [Table 7-E](#) and [Table 7-F](#).

*Note: The LOS status bit is only valid when the framer is in dual-rail (POS/NEG) interface mode. When the framer is in binary (NRZ) interface mode, LOS status must be sourced from the neighboring LIU. The reason for this is that in binary mode the neighboring LIU performs B3ZS/HDB3 decoding—substituting zeros for B3ZS/HDB3 codewords—before passing the received traffic to the framer. Because this decoded traffic can legitimately have long strings of zeros in it, the framer cannot look for and declare LOS in binary mode. In general, the IC that does the B3ZS/HDB3 decoding must provide the LOS status information.*

**Bit 1: Out-of-Frame Occurrence (OOF).** This real-time status bit is set when the framer detects an OOF condition and cleared when the OOF condition terminates. The OOF defect criteria are described in [Table 7-E](#) and [Table 7-F](#).

**Bit 2: Alarm Indication Signal Detected (AIS).** This real-time status bit is set when the framer detects an incoming AIS and cleared when the AIS condition terminates. The AIS alarm criteria are described in [Table 7-E](#) and [Table 7-F](#).

**Bit 3: Remote Alarm Indication Detected (RAI).** This real-time status bit is set when the framer detects an incoming RAI signal on the X bits or Sa bits and cleared when the RAI condition terminates. The RAI alarm criteria are described in [Table 7-E](#) and [Table 7-F](#). RAI can also be indicated through FEAC codes when the framer is operated in DS3 C-Bit Parity mode, but this bit does not indicate the FEAC alarm code detection.

**Bit 4: DS3 Idle-Signal Detected (T3IDLE).** This real-time status bit is set when the framer detects an incoming DS3 idle signal and cleared when the idle signal terminates. The DS3 idle signal alarm criteria are described in [Table 7-E](#) and [Table 7-F](#). When the framer is operated in the E3 mode, this status bit should be ignored.

**Bit 5: Severely Errored-Frame Detected (SEF).** This real-time status bit is set when the frame detects a severely errored frame condition and cleared when the SEF condition clears. The SEF defect criteria are described in [Table 7-E](#) and [Table 7-F](#).

Register Name: **T3E3SRL**  
 Register Description: **DS3/E3 Status Register Latched**  
 Register Address: **19h**

Bit #	7	6	5	4	3	2	1	0
Name	COFAL	N/A	SEFL	T3IDLEL	RAIL	AISL	OOFL	LOSL
Default	—	—	—	—	—	—	—	—

**Note:** See [Figure 7-5](#) for details on the interrupt logic for the status bits in the T3E3SRL register.

**Bit 0: Loss-of-Signal Occurrence Latched (LOSL).** This latched status bit is set to 1 when the LOS status bit in the [T3E3SR](#) register changes state (low to high or high to low). LOSL is cleared when the host processor writes a 1 to it. When LOSL is set, it can cause a hardware interrupt to occur if the LOSIE bit in the [T3E3SRIE](#) register and the T3E3IE bit in the [MSRIE](#) register are both set to 1. The interrupt is cleared when this bit is cleared or one or both of the interrupt-enable bits are cleared. See the note in the LOS status bit description for further information.

**Bit 1: Out-of-Frame Occurrence Latched (OOFL).** This latched status bit is set to 1 when the OOF status bit in the [T3E3SR](#) register changes state (low to high or high to low). OOFL is cleared when the host processor writes a 1 to it. When OOFL is set, it can cause a hardware interrupt to occur if the OOFIE bit in the [T3E3SRIE](#) register and the T3E3IE bit in the [MSRIE](#) register are both set to 1. The interrupt is cleared when this bit is cleared or one or both of the interrupt-enable bits are cleared.

**Bit 2: Alarm Indication Signal Detected Latched (AISL).** This latched status bit is set to 1 when the AIS status bit in the [T3E3SR](#) register changes state (low to high or high to low). AISL is cleared when the host processor writes a 1 to it. When AISL is set, it can cause a hardware interrupt to occur if the AISIE bit in the [T3E3SRIE](#) register and the T3E3IE bit in the [MSRIE](#) register are both set to 1. The interrupt is cleared when this bit is cleared or one or both of the interrupt-enable bits are cleared.

**Bit 3: Remote Alarm Indication Detected Latched (RAIL).** This latched status bit is set to 1 when the RAI status bit in the [T3E3SR](#) register changes state (low to high or high to low). RAIL is cleared when the host processor writes a 1 to it. When RAIL is set, it can cause a hardware interrupt to occur if the RAIIE bit in the [T3E3SRIE](#) register and the T3E3IE bit in the [MSRIE](#) register are both set to 1. The interrupt is cleared when this bit is cleared or one or both of the interrupt-enable bits are cleared.

**Bit 4: DS3 Idle-Signal-Detected Latched (T3IDLEL).** This latched status bit is set to 1 when the T3IDLE status bit in the [T3E3SR](#) register changes state (low to high or high to low). T3IDLEL is cleared when the host processor writes a 1 to it. When T3IDLEL is set, it can cause a hardware interrupt to occur if the T3IDLEIE bit in the [T3E3SRIE](#) register and the T3E3IE bit in the [MSRIE](#) register are both set to 1. The interrupt is cleared when this bit is cleared or one or both of the interrupt-enable bits are cleared.

**Bit 5: Severely Errored Frame Detected Latched (SEFL).** This latched status bit is set to 1 when the SEF status bit in the [T3E3SR](#) register changes state (low to high or high to low). SEFL is cleared when the host processor writes a 1 to it. When SEFL is set, it can cause a hardware interrupt to occur if the SEFIE bit in the [T3E3SRIE](#) register and the T3E3IE bit in the [MSRIE](#) register are both set to 1. The interrupt is cleared when this bit is cleared or one or both of the interrupt-enable bits are cleared.

**Bit 7: Change-of-Frame Alignment Latched (COFAL).** This latched status bit is set to 1 when the DS3/E3 framer has experienced a change of frame alignment (COFA). A COFA occurs when the framer achieves synchronization in a different alignment than it had previously. If the framer has never acquired synchronization before, then this status bit is meaningless. COFAL is cleared when the host processor writes a 1 to it and is not set again until the framer has lost synchronization and reacquired synchronization in a different alignment. When COFAL is set, it can cause a hardware interrupt to occur if the COFAIE bit in the [T3E3SRIE](#) register and the T3E3IE bit in the [MSRIE](#) register are both set to 1. The interrupt is cleared when this bit is cleared or one or both of the interrupt-enable bits are cleared.

Register Name: **T3E3SRIE**  
 Register Description: **DS3/E3 Status Register Interrupt Enable**  
 Register Address: **1Ah**

Bit #	7	6	5	4	3	2	1	0
Name	COFAIE	N/A	SEFIE	T3IDLEIE	RAIIE	AISIE	OOFIE	LOSIE
Default	0	—	0	0	0	0	0	0

**Bit 0: Loss-of-Signal Occurrence Interrupt Enable (LOSIE).** This bit enables an interrupt if the LOSL bit in the [T3E3SRL](#) register is set.

- 0 = interrupt disabled
- 1 = interrupt enabled

**Bit 1: Out-of-Frame Occurrence Interrupt Enable (OOFIE).** This bit enables an interrupt if the OOFL bit in the [T3E3SRL](#) register is set.

- 0 = interrupt disabled
- 1 = interrupt enabled

**Bit 2: Alarm Indication Signal Detected Interrupt Enable (AISIE).** This bit enables an interrupt if the AISL bit in the [T3E3SRL](#) register is set.

- 0 = interrupt disabled
- 1 = interrupt enabled

**Bit 3: Remote Alarm Indication Detected Interrupt Enable (RAIIE).** This bit enables an interrupt if the RAIL bit in the [T3E3SRL](#) register is set.

- 0 = interrupt disabled
- 1 = interrupt enabled

**Bit 4: DS3 Idle-Signal-Detected Interrupt Enable (T3IDLEIE).** This bit enables an interrupt if the T3IDLEL bit in the [T3E3SRL](#) register is set.

- 0 = interrupt disabled
- 1 = interrupt enabled

**Bit 5: Severely Errored Frame Detected-Interrupt Enable (SEFIE).** This bit enables an interrupt if the SEFL bit in the [T3E3SRL](#) register is set.

- 0 = interrupt disabled
- 1 = interrupt enabled

**Bit 7: Change-of-Frame Alignment Interrupt Enable (COFAIE).** This bit enables an interrupt if the COFAL bit in the [T3E3SRL](#) register is set.

- 0 = interrupt disabled
- 1 = interrupt enabled

Figure 7-5. T3E3SR Status Bit Interrupt Signal Flow

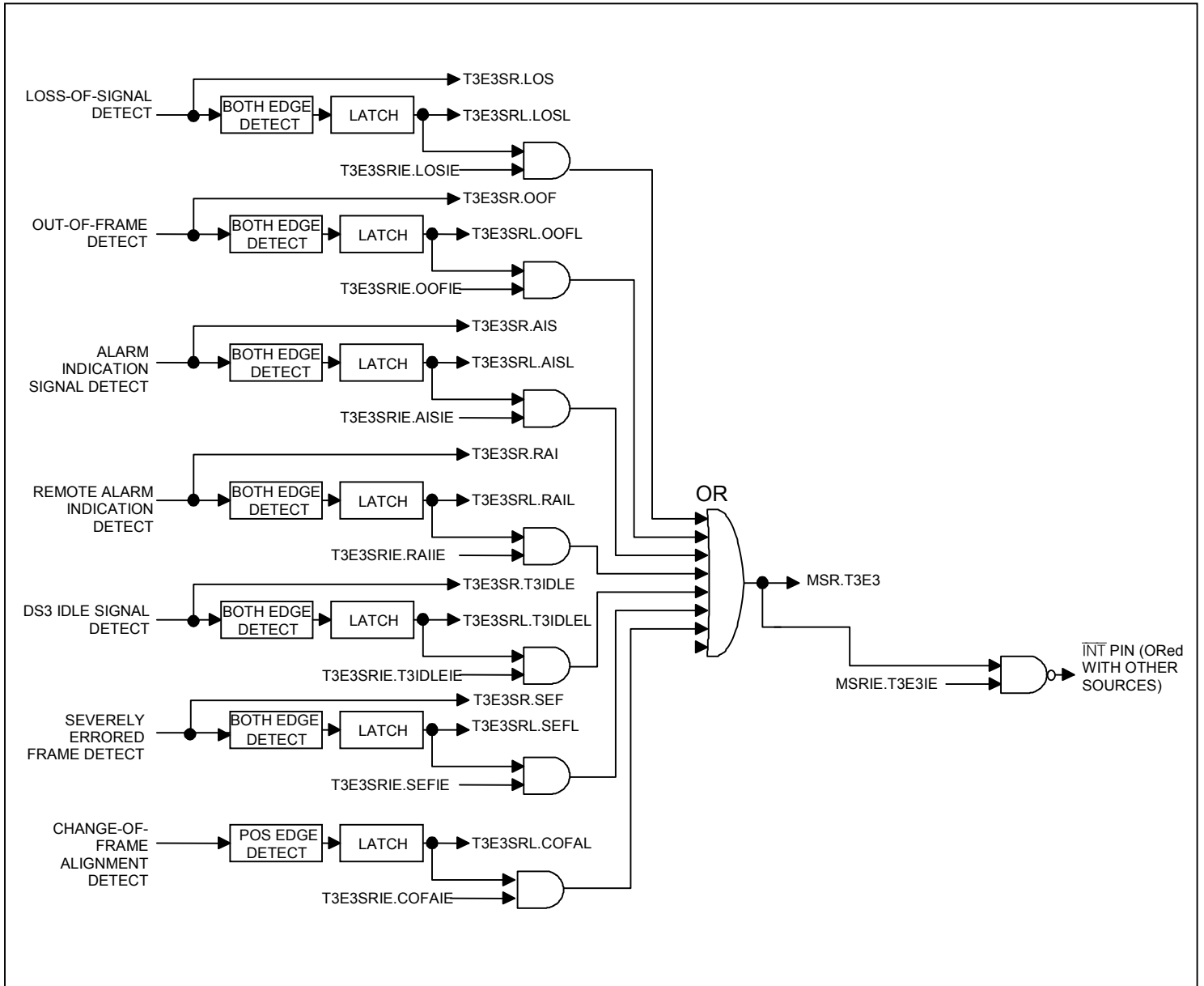



**Table 7-E. DS3 Alarm Criteria**

ALARM/ CONDITION	FUNCTION	SET CRITERIA	CLEAR CRITERIA
AIS	Alarm Indication Signal. Properly framed 1010... pattern (starting with 1 after each overhead bit), all C bits set to 0	In each 84-bit information field, the properly aligned 1010... pattern is detected with fewer than four bit errors (out of 84 possible) for 1024 consecutive information bit fields (1.95ms) and all C bits are majority decoded to be 0 during this time.	In each 84-bit information field, the properly aligned 1010... pattern is detected with four or more bit errors (out of 84 possible) for 1024 consecutive information bit fields (1.95ms)
RUA1	Unframed All-Ones	Four or fewer 0s in two consecutive 4760-bit frames	Five or more 0s in two consecutive 4760-bit frames
LOS	Loss-of-Signal	192 consecutive 0s	No EXZ events over a 192-bit window that starts with the first 1 received
OOF	Out-of-Frame. Too many F bits or M bits in error.	Three or more F bits in error out of 16 consecutive, or two or more M bits in error out of four consecutive	No errors in six consecutive sets of four F bits followed by two consecutive frames with no M bits errors, X bits matching and P bits matching
SEF	Severely Errored Frame	Three or more F bits in error out of 16 consecutive F bits	In sync (OOF = 0) and fewer than three F bits in error out of 16 consecutive F bits
RAI	Remote Alarm Indication (Also referred to as SEF/AIS in Bellcore GR-820.) X1 = X2 = 0 (active) X1 = X2 = 1 (inactive)	X1 = X2 = 0 for four consecutive M-frames (426μs)	X1 = X2 = 1 for four consecutive M-frames (426μs)
T3IDLE	DS3 Idle Signal. Properly framed 1100... pattern (starting with 11 after each overhead bit), the C bits in M-subframe 3 set to 0	In each 84-bit information field, the properly aligned 1100... pattern is detected with fewer than four bit errors (out of 84 possible) for 1024 consecutive information bit fields (1.95ms), and the C bits in M-subframe 3 are majority decoded to be 0 during this time	In each 84-bit information field, the properly aligned 1100... pattern is detected with four or more bit errors (out of 84 possible) for 1024 consecutive information bit fields (1.95ms)

**Table 7-F. E3 Alarm Criteria**

ALARM/ CONDITION	FUNCTION	SET CRITERIA	CLEAR CRITERIA
AIS	Alarm Indication Signal. Unframed all ones.	Four or fewer 0s in two consecutive 1536-bit frames	Five or more 0s in two consecutive 1536-bit frames
RUA1	Unframed All Ones	Four or fewer 0s in two consecutive 1536-bit frames	Five or more 0s in two consecutive 1536-bit frames
LOS	Loss of Signal	192 consecutive 0s	No EXZ events over a 192-bit window that starts with the first 1 received
SEF	Severely Errored Frame	Same as OOF	Same as OOF
OOF	Out-of-Frame. Too many FAS errors.	Four consecutive bad FAS	Three consecutive good FAS
RAI	Remote Alarm Indication Inactive: bit 11 of the frame = 0 Active: bit 11 of the frame = 1	Bit 11 = 1 for four consecutive frames (6144 bits, 179μs)	Bit 11 = 0 for four consecutive frames (6144 bits, 179μs)

Register Name: **T3E3IR**  
 Register Description: **DS3/E3 Information Register**  
 Register Address: **1Bh**

Bit #	7	6	5	4	3	2	1	0
Name	<u>RUA1</u>	<u>T3AIC</u>	<u>E3Sn</u>	N/A	EXZL	MBEL	FBEL	ZSCDL
Default	—	—	—	—	—	—	—	—

**Note:** The status bits in T3E3IR cannot cause a hardware interrupt to occur.

**Bit 0: Zero-Suppression Codeword-Detected Latched (ZSCDL).** This latched information bit is set to 1 when the framer detects a B3ZS/HDB3 codeword. ZSCDL is cleared when the host processor writes a 1 to it and is not set again until the framer has detected another B3ZS/HDB3 codeword. This bit has no meaning when the part is configured to operate in binary mode (BIN = 1 in the [MC1](#) register) and should be ignored. This status is still active when the ZCSD control bit is set in the [MC1](#) register.

**Bit 1: F-Bit or FAS Error-Detected Latched (FBEL).** This latched information bit is set to 1 when the framer detects an error in either the F bits (DS3 mode) or the FAS word (E3 mode). FBEL is cleared when the host processor writes a 1 to it and is not set again until the framer detects another error.

**Bit 2: M-Bit Error-Detected Latched (MBEL).** This latched information bit is set to 1 when the framer detects an error in the M bits. MBEL is cleared when the host processor writes a 1 to it and is not set again until the framer detects another error in the M bits. This status bit has no meaning in the E3 mode (DS3M = 0 in register [MC1](#)) and should be ignored.

**Bit 3: Excessive Zeros-Detected Latched (EXZL).** This latched information bit is set to 1 when the framer detects a consecutive string of either three or more 0s (DS3 mode) or four or more 0s (E3 mode). EXZL is cleared when the host processor writes a 1 to it and is not set again until the framer detects another excessive zero event. This status is not active when the framer is configured to operate in binary mode (BIN = 1 in register [MC1](#)).

**Bit 5: E3 National Bit (E3Sn).** This real-time status bit reports the incoming E3 National Bit (Sn). E3Sn is loaded at the start of each E3 frame as the Sn bit is decoded.

**Bit 6: DS3 Application ID Channel Status (T3AIC).** This real-time status bit indicates whether the incoming DS3 data stream is in C-Bit Parity format or M23 format. In the DS3 frame, the first C bit in M-subframe 1 is the application identification channel (AIC). ANSI T1.107 mandates that the AIC must be set to 1 for C-Bit Parity applications and must be toggling between 0 and 1 for M23 application (since it is a stuff control bit). The T3AIC information bit is set to 1 when the framer detects that the AIC is set to 1 for 1020 times or more out of 1024 consecutive M-frames (109ms). T3AIC is cleared when the framer detects that the AIC is set to 1 less than 1020 times out of 1024 consecutive M-frames (109ms). This status bit has no meaning in the E3 mode and should be ignored.

**Bit 7: Receive Unframed All Ones (RUA1).** This real-time status bit indicates that the framer is receiving an unframed all-ones signal. This status bit is valid in both DS3 and E3 modes and has the same function in both modes. The set and clear criteria for RUA1 are listed in [Table 7-E](#) and [Table 7-F](#).

## 7.8 DS3/E3 Performance Error Counters

There are six internal error counters and six corresponding error count registers in the DS3/E3 framer. All of the error counters and count registers are 16 bits in length. The framer can be configured to update the count registers with the latest counter values automatically once a second or manually through either the MECU bit in the [MC1](#) register or the RECU input pin. When the count registers are updated through any of these methods, the internal error counters are reset to 0. All the error counters saturate when full and do not roll over. When any of the error counters are saturated, the COVF bit is set in the [MSR](#) register.

Register Name: **BPVCR1**  
 Register Description: **Bipolar Violation Count Register 1**  
 Register Address: **20h**

Bit #	7	6	5	4	3	2	1	0
Name	<u>BPV7</u>	<u>BPV6</u>	<u>BPV5</u>	<u>BPV4</u>	<u>BPV3</u>	<u>BPV2</u>	<u>BPV1</u>	<u>BPV0</u>
Default	0	0	0	0	0	0	0	0

Register Name: **BPVCR2**  
 Register Description: **Bipolar Violation Count Register 2**  
 Register Address: **21h**

Bit #	7	6	5	4	3	2	1	0
Name	<u>BPV15</u>	<u>BPV14</u>	<u>BPV13</u>	<u>BPV12</u>	<u>BPV11</u>	<u>BPV10</u>	<u>BPV9</u>	<u>BPV8</u>
Default	0	0	0	0	0	0	0	0

**Bits 0 to 15: Bipolar Violation Count (BPV[15:0]).** This count register contains the value of the internal BPV/CV error counter latched during the last error counter update. In DS3 mode, the internal counter counts bipolar violations (BPV). In the E3 mode, the counter can be configured through the E3CVE bit in the [T3E3CR2](#) register to count BPVs or code violations (CV). A BPV is defined as consecutive pulses (or marks) of the same polarity that are not part of a B3ZS/HDB3 codeword. A CV is defined in ITU O.162 as two consecutive BPVs of the same polarity. When the line interface is in binary mode (BIN = 1 in the [MC1](#) register), the internal counter increments for each RCLK clock cycle that the RLCV pin is active. The RLCV pin is normally active high but can be inverted using the RNEGI bit in the [MC5](#) register. The BPV counter ignores the RLCV pin when the device is in diagnostic loopback (DLB = 1 in register [MC2](#)).

Register Name: **EXZCR1**  
 Register Description: **Excessive Zero Count Register 1**  
 Register Address: **22h**

Bit #	7	6	5	4	3	2	1	0
Name	<u>EXZ7</u>	<u>EXZ6</u>	<u>EXZ5</u>	<u>EXZ4</u>	<u>EXZ3</u>	<u>EXZ2</u>	<u>EXZ1</u>	<u>EXZ0</u>
Default	0	0	0	0	0	0	0	0

Register Name: **EXZCR2**  
 Register Description: **Excessive Zero Count Register 2**  
 Register Address: **23h**

Bit #	7	6	5	4	3	2	1	0
Name	<u>EXZ15</u>	<u>EXZ14</u>	<u>EXZ13</u>	<u>EXZ12</u>	<u>EXZ11</u>	<u>EXZ10</u>	<u>EXZ9</u>	<u>EXZ8</u>
Default	0	0	0	0	0	0	0	0

**Bits 0 to 15: Excessive Zero Count (EXZ[15:0]).** This count register contains the value of the internal EXZ error counter latched during the last error counter update. The internal counter counts excessive zero occurrences (EXZ). An EXZ occurrence is defined as three or more consecutive 0s in DS3 mode and four or more consecutive 0s in E3 mode. As an example, a string of eight consecutive 0s is a single EXZ occurrence and would only increment this counter once.

Register Name: **FECR1**  
 Register Description: **Frame Error Count Register 1**  
 Register Address: **24h**

Bit #	7	6	5	4	3	2	1	0
Name	<u>FE7</u>	<u>FE6</u>	<u>FE5</u>	<u>FE4</u>	<u>FE3</u>	<u>FE2</u>	<u>FE1</u>	<u>FE0</u>
Default	0	0	0	0	0	0	0	0

Register Name: **FECR2**  
 Register Description: **Frame Error Count Register 2**  
 Register Address: **25h**

Bit #	7	6	5	4	3	2	1	0
Name	<u>FE15</u>	<u>FE14</u>	<u>FE13</u>	<u>FE12</u>	<u>FE11</u>	<u>FE10</u>	<u>FE9</u>	<u>FE8</u>
Default	0	0	0	0	0	0	0	0

**Bits 0 to 15: Frame Error Count (FE[15:0]).** This count register contains the value of the internal framer error counter latched during the last error counter update. The internal counter counts either the number of OOF occurrences or the number of framing bit errors received. The type of counting is configured through the FECC[1:0] control bits in the [T3E3CR2](#) register. The possible configurations are shown below.

FECC[1:0]	Frame Error-Count Register ( <a href="#">FECR1</a> ) Configuration
00	DS3 Mode: Count OOF occurrences E3 Mode: Count OOF occurrences
01	DS3 Mode: Count both F-bit and M-bit errors E3 Mode: Count bit errors in the FAS word
10	DS3 Mode: Count only F-bit errors E3 Mode: Count word errors in the FAS word
11	DS3 Mode: Count only M-bit errors E3 Mode: Illegal state

When the counter is configured to count OOF occurrences, it increments by one each time the framer loses receive synchronization. When the counter is configured to count framing bit errors, the counter can be configured through the ECC control bit in the [T3E3CR2](#) register to either continue counting frame bit errors during an OOF event or not.

Register Name: **PCR1**  
 Register Description: **P-Bit Parity Error Count Register 1**  
 Register Address: **26h**

Bit #	7	6	5	4	3	2	1	0
Name	<u>PE7</u>	<u>PE6</u>	<u>PE5</u>	<u>PE4</u>	<u>PE3</u>	<u>PE2</u>	<u>PE1</u>	<u>PE0</u>
Default	0	0	0	0	0	0	0	0

Register Name: **PCR2**  
 Register Description: **P-Bit Parity Error Count Register 2**  
 Register Address: **27h**

Bit #	7	6	5	4	3	2	1	0
Name	<u>PE15</u>	<u>PE14</u>	<u>PE13</u>	<u>PE12</u>	<u>PE11</u>	<u>PE10</u>	<u>PE9</u>	<u>PE8</u>
Default	0	0	0	0	0	0	0	0

**Bits 0 to 15: P-Bit Parity Error Count (PE[15:0]).** This count register contains the value of the internal P-bit parity error counter latched during the last error counter update. The internal counter counts the number of DS3 P-bit parity errors. In E3 mode this counter is meaningless and should be ignored. A P-bit parity error is defined as an occurrence when the two P bits in a DS3 frame do not match one another or when the two P bits do not match the parity calculation made on the information bits. Through the ECC control bit in the [T3E3CR2](#) register, the counter can be configured to either continue counting P-bit parity errors during an OOF event or not.

Register Name: **CPCR1**  
 Register Description: **CP-Bit Parity Error Count Register 1**  
 Register Address: **28h**

Bit #	7	6	5	4	3	2	1	0
Name	<u>CPE7</u>	<u>CPE6</u>	<u>CPE5</u>	<u>CPE4</u>	<u>CPE3</u>	<u>CPE2</u>	<u>CPE1</u>	<u>CPE0</u>
Default	0	0	0	0	0	0	0	0

Register Name: **CPCR2**  
 Register Description: **CP-Bit Parity Error Count Register 2**  
 Register Address: **29h**

Bit #	7	6	5	4	3	2	1	0
Name	<u>CPE15</u>	<u>CPE14</u>	<u>CPE13</u>	<u>CPE12</u>	<u>CPE11</u>	<u>CPE10</u>	<u>CPE9</u>	<u>CPE8</u>
Default	0	0	0	0	0	0	0	0

**Bits 0 to 15: CP-Bit Parity Error Count (CPE[15:0]).** This count register contains the value of the internal CP-bit parity error counter latched during the last error counter update. The internal counter counts the number of DS3 CP-bit parity errors. In E3 mode or M23 DS3 mode this counter is meaningless and should be ignored. A CP-bit parity error is defined as an occurrence when the majority-decoded state of the three CP bits does not match the parity calculation made on the information bits. Through the ECC control bit in the [T3E3CR2](#) register, the counter can be configured to either continue counting CP-bit parity bit errors during an OOF event or not.

Register Name: **FEBCR1**  
 Register Description: **Far-End Block Error Count Register 1**  
 Register Address: **2Ah**

Bit #	7	6	5	4	3	2	1	0
Name	<u>FEBE7</u>	<u>FEBE6</u>	<u>FEBE5</u>	<u>FEBE4</u>	<u>FEBE3</u>	<u>FEBE2</u>	<u>FEBE1</u>	<u>FEBE0</u>
Default	0	0	0	0	0	0	0	0

Register Name: **FEBCR2**  
 Register Description: **Far-End Block Error Count Register 2**  
 Register Address: **2Bh**

Bit #	7	6	5	4	3	2	1	0
Name	<u>FEBE15</u>	<u>FEBE14</u>	<u>FEBE13</u>	<u>FEBE12</u>	<u>FEBE11</u>	<u>FEBE10</u>	<u>FEBE9</u>	<u>FEBE8</u>
Default	0	0	0	0	0	0	0	0

**Bits 0 to 15: Far-End Block Error Count (FEBE[15:0]).** This count register contains the value of the internal FEBE counter latched during the last error counter update. The internal counter counts the number of DS3 far-end block errors (FEBE). In E3 mode or M23 DS3 mode this counter is meaningless and should be ignored. A FEBE is defined as an occurrence when the three received FEBE bits do not equal 111. Through the ECC control bit in the [T3E3CR2](#) register, the counter can be configured to either continue counting FEBE occurrences during an OOF event or not.

## 7.9 BERT

The BERT block can generate and detect the following patterns:

- Maximal-length pseudorandom patterns up to  $2^{31} - 1$
- A repetitive pattern from 1 to 32 bits in length
- Alternating (16-bit) words that alternate every 1 to 256 words

The BERT receiver has a 24-bit error counter and 32-bit bit counter to allow testing to proceed for long periods without host processor intervention. It can generate interrupts on detecting a bit error, a change in synchronization, or a counter overflow. The BERT can be selected to transmit and receive on the line side or the equipment side. The synchronization algorithm works on a 32-bit block of data, not in a sliding window fashion.

The DS3/E3 formatter can be configured to transmit AIS when the BERT is not being used to test the far end, such as when DLB is active or when  $BM[1:0] = 1X$ . When DLB is active, the BERT is used to test the inner workings of the chip, and when  $BM[1:0] = 1X$ , the BERT is used to test devices connected on the equipment side (TDAT and RDAT). In either case, BERT patterns are transmitted to the far end on TPOS and TNEG unless the DS3/E3 formatter is configured to transmit AIS by setting [T3E3CR1:TAIS](#) = 1.

**Table 7-G. BERT Register Map**

ADDR	REGISTER	BIT 7	BIT 6	BIT 5	BIT 4	BIT 3	BIT 2	BIT 1	BIT 0
30h	<a href="#">BCR1</a>	BM1	BM0	BENA	TINV	RINV	RESYNC	TC	LC
31h	<a href="#">BCR2</a>	N/A	PS2	PS1	PS0	RPL3	RPL2	RPL1	RPL0
32h	<a href="#">BCR3</a>	N/A	N/A	N/A	N/A	EIB2	EIB1	EIB0	SBE
33h	<a href="#">BCR4</a>	AWC7	AWC6	AWC5	AWC4	AWC3	AWC2	AWC1	AWC0
38h	<a href="#">BSR</a>	N/A	N/A	<a href="#">RA1</a>	<a href="#">RA0</a>	N/A	<a href="#">BBCO</a>	<a href="#">BECO</a>	<a href="#">SYNC</a>
39h	<a href="#">BSRL</a>	N/A	N/A	<a href="#">RA1L</a>	<a href="#">RA0L</a>	BEDL	BBCOL	BECOL	SYNCL
3Ah	<a href="#">BSRIE</a>	N/A	N/A	N/A	N/A	BEDIE	BBCOIE	BECOIE	SYNCIE
3Ch	<a href="#">BRPR1</a>	RP7	RP6	RP5	RP4	RP3	RP2	RP1	RP0
3Dh	<a href="#">BRPR2</a>	RP15	RP14	RP13	RP12	RP11	RP10	RP9	RP8
3Eh	<a href="#">BRPR3</a>	RP23	RP22	RP21	RP20	RP19	RP18	RP17	RP16
3Fh	<a href="#">BRPR4</a>	RP31	RP30	RP29	RP28	RP27	RP26	RP25	RP24
40h	<a href="#">BBCR1</a>	<a href="#">BBC7</a>	<a href="#">BBC6</a>	<a href="#">BBC5</a>	<a href="#">BBC4</a>	<a href="#">BBC3</a>	<a href="#">BBC2</a>	<a href="#">BBC1</a>	<a href="#">BBC0</a>
41h	<a href="#">BBCR2</a>	<a href="#">BBC15</a>	<a href="#">BBC14</a>	<a href="#">BBC13</a>	<a href="#">BBC12</a>	<a href="#">BBC11</a>	<a href="#">BBC10</a>	<a href="#">BBC9</a>	<a href="#">BBC8</a>
42h	<a href="#">BBCR3</a>	<a href="#">BBC23</a>	<a href="#">BBC22</a>	<a href="#">BBC21</a>	<a href="#">BBC20</a>	<a href="#">BBC19</a>	<a href="#">BBC18</a>	<a href="#">BBC17</a>	<a href="#">BBC16</a>
43h	<a href="#">BBCR4</a>	<a href="#">BBC31</a>	<a href="#">BBC30</a>	<a href="#">BBC29</a>	<a href="#">BBC28</a>	<a href="#">BBC27</a>	<a href="#">BBC26</a>	<a href="#">BBC25</a>	<a href="#">BBC24</a>
44h	<a href="#">BBECR1</a>	<a href="#">BEC7</a>	<a href="#">BEC6</a>	<a href="#">BEC5</a>	<a href="#">BEC4</a>	<a href="#">BEC3</a>	<a href="#">BEC2</a>	<a href="#">BEC1</a>	<a href="#">BEC0</a>
45h	<a href="#">BBECR2</a>	<a href="#">BEC15</a>	<a href="#">BEC14</a>	<a href="#">BEC13</a>	<a href="#">BEC12</a>	<a href="#">BEC11</a>	<a href="#">BEC10</a>	<a href="#">BEC9</a>	<a href="#">BEC8</a>
46h	<a href="#">BBECR3</a>	<a href="#">BEC23</a>	<a href="#">BEC22</a>	<a href="#">BEC21</a>	<a href="#">BEC20</a>	<a href="#">BEC19</a>	<a href="#">BEC18</a>	<a href="#">BEC17</a>	<a href="#">BEC16</a>

Register Name: **BCR1**  
 Register Description: **BERT Control Register 1**  
 Register Address: **30h**

Bit #	7	6	5	4	3	2	1	0
Name	BM1	BM0	BENA	TINV	RINV	RESYNC	TC	LC
Default	0	0	0	0	0	0	0	0

**Bit 0: Load Bit and Error Counts (LC).** A low-to-high transition latches the current bit and error counts into the host-processor-accessible registers BCCR and BBECR and then clears the internal counters. This bit should be toggled from low to high whenever the host processor wishes to begin a new acquisition period. Must be cleared and set again for subsequent loads.

**Bit 1: Transmit Pattern Load (TC).** A low-to-high transition loads the pattern generator. This bit should be toggled from low to high whenever the host processor loads a new pattern or needs to resynchronize to an existing pattern. Must be cleared and set again for subsequent loads. For pseudorandom patterns, PS[2:0] must be configured before toggling TC. For repetitive patterns, PS[2:0], RPL[3:0], and RP[31:0] must be configured before toggling TC. For alternating word patterns, PS[2:0], AWC[7:0], and RP[31:0] must be configured before toggling TC.

**Bit 2: Force Resynchronization (RESYNC).** A low-to-high transition forces the receive BERT synchronizer to resynchronize to the incoming data stream. This bit should be toggled from low to high whenever the host processor wishes to acquire synchronization on a new pattern. Must be cleared and set again for a subsequent resynchronization.

**Bit 3: Receive Invert Data Enable (RINV)**

0 = do not invert the incoming data stream

1 = invert the incoming data stream

**Bit 4: Transmit Invert Data Enable (TINV)**

0 = do not invert the outgoing data stream

1 = invert the outgoing data stream

**Bit 5: BERT Enable (BENA).** This bit is used to enable the BERT transmitter, replacing the payload, or the entire DS3/E3 signal (depending on the setting of BM[1:0]). The BERT receiver is always enabled. Configure all BERT control and pattern registers and toggle the TC control bit before setting BENA.

0 = disable BERT transmitter

1 = enable BERT transmitter

**Bits 6, 7: BERT Mode (BM[1:0]).** These bits select whether the BERT pattern replaces only the DS3/E3 payload or the entire DS3/E3 frame (payload and overhead). These bits also select the BERT transmit direction: line side (TPOS/TNEG and RPOS/RNEG) or equipment side (TDAT and RDAT).

BM[1:0]	DATA	TRANSMIT	RECEIVE
00	Payload	TPOS/TNEG	RPOS/RNEG
01	Entire frame	TPOS/TNEG	RPOS/RNEG
10	Payload	RDAT	TDAT
11	Entire frame	RDAT	TDAT

Register Name: **BCR2**  
 Register Description: **BERT Control Register 2**  
 Register Address: **31h**

Bit #	7	6	5	4	3	2	1	0
Name	N/A	PS2	PS1	PS0	RPL3	RPL2	RPL1	RPL0
Default	—	0	0	0	0	0	0	0

**Bits 0 to 3: Repetitive Pattern Length (RPL[3:0]).** RPL3 is the MSB and RPL0 is the LSB of a nibble that describes how long the repetitive pattern is. The valid range is 17 (0000) to 32 (1111). These bits are ignored if the BERT is programmed for a pseudorandom pattern or an alternating word pattern. To create repetitive patterns fewer than 17 bits in length, the user must set the length to an integer multiple of the desired length that is less than or equal to 32. For example, to create a 6-bit pattern, set the length to 18 (0001), 24 (0111), or 30 (1101).

Length	Code	Length	Code	Length	Code	Length	Code
17 bits	0000	18 bits	0001	19 bits	0010	20 bits	0011
21 bits	0100	22 bits	0101	23 bits	0110	24 bits	0111
25 bits	1000	26 bits	1001	27 bits	1010	28 bits	1011
29 bits	1100	30 bits	1101	31 bits	1110	32 bits	1111

**Bits 4 to 6: Pattern Select (PS[2:0]).** This field specifies the type of pattern to be generated. After configuring these bits, the TC bit in the [BCR1](#) register must be toggled to reconfigure the pattern generator.

PS[2:0]	PATTERN	TAPS	SPECIFICATION	TINV	RINV
000	Repetitive Pattern	—	—	—	—
001	Alternating Word Pattern	—	—	—	—
010	$2^{15} - 1$	14, 15	ITU O.151 (for DS3)	1	1
011	$2^{20} - 1$ QRSS	17, 20	T1.403	0	0
100	$2^{23} - 1$	18, 23	ITU O.151 (for E3)	1	1
101	$2^{31} - 1$	28, 31	(none)	0	0
110	Invalid	—	—	—	—
111	Invalid	—	—	—	—

Register Name: **BCR3**  
 Register Description: **BERT Control Register 3**  
 Register Address: **32h**

Bit #	7	6	5	4	3	2	1	0
Name	N/A	N/A	N/A	N/A	EIB2	EIB1	EIB0	SBE
Default	—	—	—	—	0	0	0	0

**Bit 0: Single Bit-Error Insert (SBE).** A low-to-high transition creates a single bit error. Must be cleared and set again for a subsequent bit error to be inserted.

**Bits 1 to 3: Error Insert Bits (EIB[2:0]).** Automatically insert bit errors at the prescribed rate into the generated data pattern. Useful for verifying error detection operation.

EIB[2:0]	ERROR RATE INSERTED
000	No errors automatically inserted
001	$10^{-1}$ (1 error per 10 bits)
010	$10^{-2}$ (1 error per 100 bits)
011	$10^{-3}$ (1 error per 1000 bits)
100	$10^{-4}$ (1 error per 10,000 bits)
101	$10^{-5}$ (1 error per 100,000 bits)
110	$10^{-6}$ (1 error per 1,000,000 bits)
111	$10^{-7}$ (1 error per 10,000,000 bits)



Register Name: **BCR4**  
 Register Description: **BERT Control Register 4**  
 Register Address: **33h**

Bit #	7	6	5	4	3	2	1	0
Name	AWC7	AWC6	AWC5	AWC4	AWC3	AWC2	AWC1	AWC0
Default	0	0	0	0	0	0	0	0

**Bits 0 to 7: Alternating Word Count Rate (AWC[7:0]).** When the BERT is programmed in the alternating word mode, it transmits the word in register RP[15:0] a number of times equal to AWC[7:0] + 1 and then transmits the word loaded in RP[31:16] the same number of times. The valid count range is from 00h to FFh. These bits are ignored if the BERT is programmed for a pseudorandom pattern or a repetitive pattern.

AWC VALUE	ALTERNATING COUNT ACTION
00h	Send the word in RP[15:0] <b>1</b> time followed by the word in RP[31:16] <b>1</b> time...
01h	Send the word in RP[15:0] <b>2</b> times followed by the word in RP[31:16] <b>2</b> times...
02h	Send the word in RP[15:0] <b>3</b> times followed by the word in RP[31:16] <b>3</b> times...
.	.
.	.
FFh	Send the word in RP[15:0] <b>256</b> times followed by the word in RP[31:16] <b>256</b> times...

Register Name: **BSR**  
 Register Description: **BERT Status Register**  
 Register Address: **38h**

Bit #	7	6	5	4	3	2	1	0
Name	N/A	N/A	<u>RA1</u>	<u>RA0</u>	N/A	<u>BBCO</u>	<u>BECO</u>	<u>SYNC</u>
Default	—	—	—	—	—	—	—	—

**Bit 0: Synchronization Status (SYNC).** This real-time status bit is set when the incoming pattern matches for 32 consecutive bit positions. SYNC bit is cleared when six or more bits out of 64 are received in error.

**Bit 1: BERT Error-Counter Overflow (BECO).** This real-time status bit is set when the 24-bit BERT error counter (BEC) saturates. BECO is cleared when [BCR1:LC](#) is toggled to load the error counts.

**Bit 2: BERT Bit-Counter Overflow (BBCO).** This real-time status bit is set when the 32-bit BERT bit counter (BBC) saturates. BBCO is cleared when [BCR1:LC](#) is toggled to load the error counts.

**Bit 4: Receive All Zeros (RA0).** This real-time status bit is set when 32 consecutive 0s are received. RA0 is cleared when a 1 is received.

**Bit 5: Receive All Ones (RA1).** This real-time status bit is set when 32 consecutive 1s are received. RA1 is cleared when a 0 is received.

Register Name: **BSRL**  
 Register Description: **BERT Status Register Latched**  
 Register Address: **39h**

Bit #	7	6	5	4	3	2	1	0
Name	N/A	N/A	RA1L	RA0L	BEDL	BBCOL	BECOL	SYNCL
Default	—	—	—	—	—	—	—	—

**Note:** See [Figure 7-6](#) for details on the interrupt logic for the status bits in the BSRL register.

**Bit 0: Synchronization Status Latched (SYNCL).** This latched status bit is set to 1 when the SYNC status bit in the [BSR](#) register changes state (low to high or high to low). To determine if this bit was set because of finding synchronization or losing synchronization, read the SYNC real-time status bit in the [BSR](#) register. SYNCL is cleared when the host processor writes a 1 to it and is not set again until SYNC changes state again. When SYNCL is set, it can cause a hardware interrupt to occur if the SYNCIE bit in the [BSRIE](#) register and the BERTIE bit in the [MSRIE](#) register are both set to 1. The interrupt is cleared when this bit is cleared or one or both of the interrupt-enable bits are cleared.

**Bit 1: BERT Error-Counter Overflow Latched (BECOL).** This latched status bit is set to 1 when the BECO status bit in the [BSR](#) register goes high. BECOL is cleared when the host processor writes a one to it and is not set again until BECO goes high again. When BECOL is set, it can cause a hardware interrupt to occur if the BECOIE bit in the [BSRIE](#) register and the BERTIE bit in the [MSRIE](#) register are both set to a 1. The interrupt is cleared when this bit is cleared or one or both of the interrupt-enable bits are cleared.

**Bit 2: BERT Bit-Counter Overflow Latched (BBCOL).** This latched status bit is set to 1 when the BBCO status bit in the [BSR](#) register goes high. BBCOL is cleared when the host processor writes a 1 to it and is not set again until BBCO goes high again. When BBCOL is set, it can cause a hardware interrupt to occur if the BBCOIE bit in the [BSRIE](#) register and the BERTIE bit in the [MSRIE](#) register are both set to 1. The interrupt is cleared when this bit is cleared or one or both of the interrupt-enable bits are cleared.

**Bit 3: Bit Error-Detected Latched (BEDL).** This latched status bit is set to 1 when a bit error is detected. The receive BERT must be in synchronization to detect bit errors. BEDL is cleared when the host processor writes a 1 to it. When BEDL is set it can cause a hardware interrupt to occur if the BEDIE bit in the [BSRIE](#) register and the BERTIE bit in the [MSRIE](#) register are both set to 1. The interrupt is cleared when this bit is cleared or one or both of the interrupt-enable bits are cleared.

**Bit 4: Receive All-Zeros Latched (RA0L).** This latched status bit is set to 1 when the RA0 bit in the [BSR](#) register is set. RA0L is cleared when the host processor writes a 1 to it. RA0L cannot cause an interrupt.

**Bit 5: Receive All-Ones Latched (RA1L).** This latched status bit is set to 1 when the RA1 bit in the [BSR](#) register is set. RA1L is cleared when the host processor writes a 1 to it. RA1L cannot cause an interrupt.

Register Name: **BSRIE**  
 Register Description: **BERT Status Register Interrupt Enable**  
 Register Address: **3Ah**

Bit #	7	6	5	4	3	2	1	0
Name	N/A	N/A	N/A	N/A	BEDIE	BBCOIE	BECOIE	SYNCIE
Default	—	—	—	—	0	0	0	0

**Bit 0: Synchronization Status Interrupt Enable (SYNCIE).** This bit enables an interrupt if the SYNCL bit in the [BSRL](#) register is set.

- 0 = interrupt disabled
- 1 = interrupt enabled

**Bit 1: BERT Error-Counter Overflow Interrupt Enable (BECOIE).** This bit enables an interrupt if the BECOL bit in the [BSRL](#) register is set.

- 0 = interrupt disabled
- 1 = interrupt enabled

**Bit 2: BERT Bit-Counter Overflow Interrupt Enable (BBCOIE).** This bit enables an interrupt if the BBCOL bit in the [BSRL](#) register is set.

- 0 = interrupt disabled
- 1 = interrupt enabled

**Bit 3: Bit Error-Detected Interrupt Enable (BEDIE).** This bit enables an interrupt if the BEDL bit in the [BSRL](#) register is set.

- 0 = interrupt disabled
- 1 = interrupt enabled

**Figure 7-6. BERT Status Bit Interrupt Signal Flow**

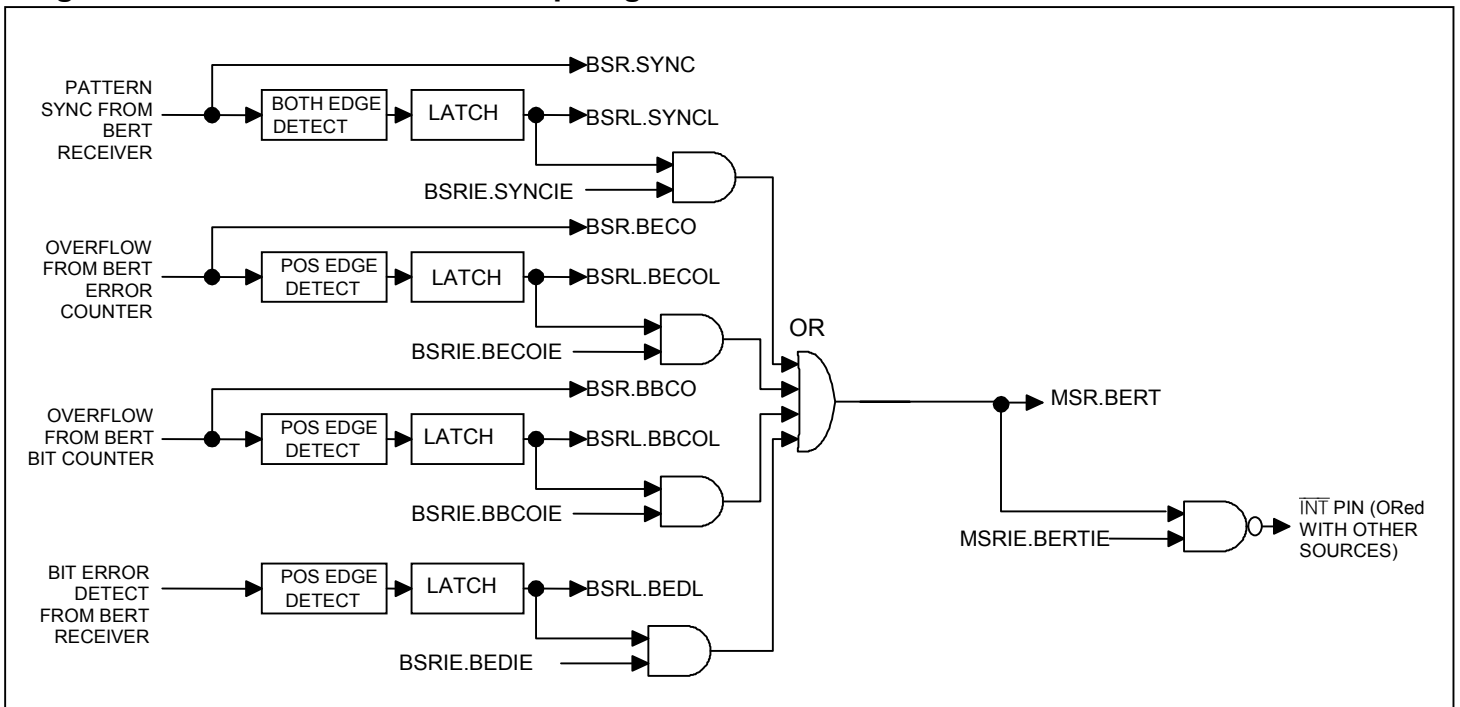

Register Name: **BRPR1**  
 Register Description: **BERT Repetitive Pattern Register 1 (lower byte)**  
 Register Address: **3Ch**

Bit #	7	6	5	4	3	2	1	0
Name	RP7	RP6	RP5	RP4	RP3	RP2	RP1	RP0
Default	0	0	0	0	0	0	0	0

Register Name: **BRPR2**  
 Register Description: **BERT Repetitive Pattern Register 2**  
 Register Address: **3Dh**

Bit #	7	6	5	4	3	2	1	0
Name	RP15	RP14	RP13	RP12	RP11	RP10	RP9	RP8
Default	0	0	0	0	0	0	0	0

Register Name: **BRPR3**  
 Register Description: **BERT Repetitive Pattern Register 3**  
 Register Address: **3Eh**

Bit #	7	6	5	4	3	2	1	0
Name	RP23	RP22	RP21	RP20	RP19	RP18	RP17	RP16
Default	0	0	0	0	0	0	0	0

Register Name: **BRPR4**  
 Register Description: **BERT Repetitive Pattern Register 4 (upper byte)**  
 Register Address: **3Fh**

Bit #	7	6	5	4	3	2	1	0
Name	RP31	RP30	RP29	RP28	RP27	RP26	RP25	RP24
Default	0	0	0	0	0	0	0	0

**Bits 0 to 31: BERT Repetitive Pattern (RP[31:0]).** These registers must be configured for the BERT to properly generate and synchronize to a repetitive pattern or an alternating word pattern. For an alternating word pattern, the first word to be transmitted should be placed into RP[15:0], and the second word should be placed into RP[31:16]. In the first word, RP0 is the LSB and is transmitted first. In the second word, RP16 is the LSB and is transmitted first. For repetitive patterns, RP0 is the LSB and is transmitted first, while the MSB is determined by the repetitive pattern length, RPL[3:0].

An alternating word example: To use the DDS stress pattern "7E," set BRPR1 = BRPR2 = 00h, BRPR3 = BRPR4 = 7Eh. When AWC[7:0] is set to 49 (decimal), the BERT sends and detects  $(49 + 1) \times 2 = 100$  bytes of 00h followed by 100 bytes of 7Eh.

Register Name: **BBCR1**  
 Register Description: **BERT Bit Counter Register 1 (lower byte)**  
 Register Address: **40h**

Bit #	7	6	5	4	3	2	1	0
Name	<u>BBC7</u>	<u>BBC6</u>	<u>BBC5</u>	<u>BBC4</u>	<u>BBC3</u>	<u>BBC2</u>	<u>BBC1</u>	<u>BBC0</u>
Default	0	0	0	0	0	0	0	0

Register Name: **BBCR2**  
 Register Description: **BERT Bit Counter Register 2**  
 Register Address: **41h**

Bit #	7	6	5	4	3	2	1	0
Name	<u>BBC15</u>	<u>BBC14</u>	<u>BBC13</u>	<u>BBC12</u>	<u>BBC11</u>	<u>BBC10</u>	<u>BBC9</u>	<u>BBC8</u>
Default	0	0	0	0	0	0	0	0

Register Name: **BBCR3**  
 Register Description: **BERT Bit Counter Register 3**  
 Register Address: **42h**

Bit #	7	6	5	4	3	2	1	0
Name	<u>BBC23</u>	<u>BBC22</u>	<u>BBC21</u>	<u>BBC20</u>	<u>BBC19</u>	<u>BBC18</u>	<u>BBC17</u>	<u>BBC16</u>
Default	0	0	0	0	0	0	0	0

Register Name: **BBCR4**  
 Register Description: **BERT Bit Counter Register 4 (upper byte)**  
 Register Address: **43h**

Bit #	7	6	5	4	3	2	1	0
Name	<u>BBC31</u>	<u>BBC30</u>	<u>BBC29</u>	<u>BBC28</u>	<u>BBC27</u>	<u>BBC26</u>	<u>BBC25</u>	<u>BBC24</u>
Default	0	0	0	0	0	0	0	0

**Bits 0 to 31: BERT Bit Counter (BBC[31:0]).** The BBCR registers are loaded with the value of the internal BERT bit counter when the LC control bit in the [BCR1](#) register is toggled. This 32-bit counter increments for each data bit received. The bit counter starts counting when the BERT goes into receive synchronization (SYNC = 1) and continues counting even if the BERT loses sync. The bit counter saturates and does not roll over. Upon saturation, the BBCO status bit in the [BSR](#) register is set. When the LC bit is toggled, the bit count is loaded into the BBCR registers and the internal bit counter is cleared. If the BERT is in sync when LC is toggled, the bit counter continues to count up from zero. If the BERT is out of sync when LC is toggled, the bit counter is held at zero until the BERT regains sync. The host processor should toggle LC after the BERT has synchronized and then toggle LC again when the error-checking period is complete. If the framer loses synchronization during this period, then the counting results are suspect.

Register Name: **BBECR1**  
 Register Description: **BERT Bit-Error Counter Register 1 (lower byte)**  
 Register Address: **44h**

Bit #	7	6	5	4	3	2	1	0
Name	<u>BEC7</u>	<u>BEC6</u>	<u>BEC5</u>	<u>BEC4</u>	<u>BEC3</u>	<u>BEC2</u>	<u>BEC1</u>	<u>BEC0</u>
Default	0	0	0	0	0	0	0	0

Register Name: **BBECR2**  
 Register Description: **BERT Bit Error Counter Register 2**  
 Register Address: **45h**

Bit #	7	6	5	4	3	2	1	0
Name	<u>BEC15</u>	<u>BEC14</u>	<u>BEC13</u>	<u>BEC12</u>	<u>BEC11</u>	<u>BEC10</u>	<u>BEC9</u>	<u>BEC8</u>
Default	0	0	0	0	0	0	0	0

Register Name: **BBECR3**  
 Register Description: **BERT Bit Error Counter Register 3 (upper byte)**  
 Register Address: **46h**

Bit #	7	6	5	4	3	2	1	0
Name	<u>BEC23</u>	<u>BEC22</u>	<u>BEC21</u>	<u>BEC20</u>	<u>BEC19</u>	<u>BEC18</u>	<u>BEC17</u>	<u>BEC16</u>
Default	0	0	0	0	0	0	0	0

**Bits 0 to 23: BERT Bit-Error Counter (BEC[23:0]).** The BBECR registers are loaded with the value of the internal BERT error counter when the LC control bit in the [BCR1](#) register is toggled. This 24-bit counter increments for each received data bit that does not match the expected pattern. The error counter starts counting when the BERT goes into receive synchronization (SYNC = 1) and continues counting even if the BERT loses sync. The error counter saturates and does not roll over. Upon saturation, the BECO status bit in the [BSR](#) register is set. When the LC bit is toggled, the error count is loaded into the BBECR registers and the internal error counter is cleared. If the BERT is in sync when LC is toggled, the error counter continues to count up from zero. If the BERT is out of sync when LC is toggled, the error counter is held at zero until the BERT regains sync. The host processor should toggle LC after the BERT has synchronized and then toggle LC again when the error-checking period is complete. If the framer loses synchronization during this period, then the counting results are suspect.

## 7.10 HDLC Controller

Each framer contains an on-board HDLC controller with 256-byte buffers in both the transmit and receive paths. When the framer is operated in the DS3 C-Bit Parity mode, the HDLC transmitter and receiver are connected to the three C-bits in M-subframe 5. When the framer is operated in the E3 mode, the user has the option to connect the HDLC transmitter to the Sn bit, while the HDLC receiver is always connected to the Sn bit in the receive data. If the host processor does not wish to use the HDLC controller for the Sn bit, then the status provided by the HDLC controller should be ignored. On the transmit side, the host processor selects the source of the Sn bit through the E3SnC0 and E3SnC1 controls bits in the [T3E3CR1](#) register. The HDLC controller is not used in the DS3 M23 mode.

### 7.10.1 Receive Operation

On reset, the receive HDLC controller flushes the receive FIFO and begins searching for a new incoming HDLC packet. It then performs a bit-by-bit search for an HDLC packet and when one is detected, it zero destuffs the incoming data stream, automatically byte aligns to it, and places the incoming bytes into the receive FIFO as they are received. The first byte of each packet is marked in the receive FIFO by setting the opening byte (OBYTE) bit. Upon detecting a closing flag, the receive HDLC controller checks the 16-bit CRC to see if the packet is valid or not and then marks the last byte of the packet in the receive FIFO by setting the closing byte (CBYTE) bit. The CRC is not passed to the receive FIFO. When the CBYTE bit is set, the host processor can obtain the status of the incoming packet through the packet status bits (PS0 and PS1). Incoming packets can be separated by as few as one flag or by two flags that share a common zero. If the receive FIFO ever fills beyond capacity, the rest of the incoming packet data is discarded, and the receive FIFO overrun (ROVRL) status bit is set. If such a scenario

occurs, then the last packet in the FIFO is suspect and should be discarded. When an overflow occurs, the receive HDLC controller stops accepting packets until either the FIFO is completely emptied or reset. If the receive HDLC detects an incoming abort (seven or more 1s in a row), it sets the receive abort sequence-detected (RABTL) status bit. If an abort sequence is detected in the middle of an incoming packet, then the receive HDLC controller sets the packet status bits accordingly in the receive FIFO.

The receive HDLC controller has been designed to minimize its real-time host processor support requirements. The 256-byte receive FIFO is deep enough to store the three DS3 packets (path ID, idle signal ID, and test signal ID) that arrive once a second. Thus, in DS3 applications the host processor only needs to read the receive HDLC FIFO once a second to retrieve the three messages. The host processor can be notified when the beginning of a new packet is received (receive packet start status bit) and when the end of a packet is received (receive packet end status bit). Also, the host processor can be notified when the FIFO has filled beyond a programmable level called the high watermark. The host processor reads the incoming packet data out of the receive FIFO one byte at a time. When the receive FIFO is empty, the EMPTY bit in the HDLC information register (HIR) is set.

### 7.10.2 Transmit Operation

On reset, the transmit HDLC controller flushes the transmit FIFO and transmits an abort followed by either 7Eh or FFh (depending on the setting of the TFS control bit) continuously. The transmit HDLC controller then waits until there are at least two bytes in the transmit FIFO before starting to send the packet. The transmit HDLC automatically adds an opening flag of 7Eh to the beginning of the packet and zero stuffs the outgoing data stream. When the transmit HDLC controller detects that the TMEND bit in the transmit FIFO is set, it automatically calculates and appends the 16-bit CRC checksum followed by a closing flag of 7Eh. If the FIFO is empty, the transmit HDLC controller sends either 7Eh or FFh continuously. When new data arrives in the FIFO, the transmit HDLC automatically transmits the opening flag and begins sending the next packet. Between consecutive packets, there are always at least two flags. If the transmit FIFO ever empties when a packet is being sent (i.e., before the TMEND bit is set), then the transmit HDLC controller sets the transmit FIFO underrun (TUDRL) status bit and sends an abort of seven 1s in a row (FEh) followed by continuous transmission of either 7Eh (flags) or FFh (idle). When the FIFO underruns, the transmit HDLC controller should be reset by the host processor.

The transmit HDLC controller has been designed to minimize its real-time host processor support requirements. The 256-byte transmit FIFO is deep enough to store the three DS3 packets (path ID, idle signal ID, and test signal ID) that should be sent once a second. Thus, in DS3 applications the host processor only needs to write the transmit HDLC FIFO once a second to send the three messages. Once the host processor has written an outgoing packet, it can monitor the transmit packet-end (TENDL) status bit to know when the packet has been sent. Also, the host processor can be notified when the FIFO has emptied below a programmable level called the low watermark. The host processor must never overfill the FIFO. To keep this from occurring, the host processor can obtain the real-time depth of the transmit FIFO through the transmit FIFO level bits in the HDLC information register (HIR).

**Table 7-H. HDLC Register Map**

ADDR	REGISTER	BIT 7	BIT 6	BIT 5	BIT 4	BIT 3	BIT 2	BIT 1	BIT 0
50h	<a href="#">HCR1</a>	RHR	THR	RID	TID	TFS	TZSD	TCRCI	TCRCD
51h	<a href="#">HCR2</a>	N/A	RHWMS2	RHWMS1	RHWMS0	N/A	TLWMS2	TLWMS1	TLWMS0
54h	<a href="#">HSR</a>	N/A	N/A	N/A	N/A	<a href="#">RHWM</a>	<a href="#">TLWM</a>	N/A	N/A
55h	<a href="#">HSRL</a>	ROVRL	RPEL	RPSL	RABTL	RHWML	TLWML	TUDRL	TENDL
56h	<a href="#">HSRIE</a>	ROVRIE	RPEIE	RPSIE	RABTIE	RHWMIE	TLWMIE	TUDRIE	TENDIE
57h	<a href="#">HIR</a>	N/A	N/A	<a href="#">EMPTY</a>	<a href="#">EMPTY</a>	<a href="#">TFL3</a>	<a href="#">TFL2</a>	<a href="#">TFL1</a>	<a href="#">TFL0</a>
5Ch	<a href="#">RHDLC1</a>	<a href="#">D7</a>	<a href="#">D6</a>	<a href="#">D5</a>	<a href="#">D4</a>	<a href="#">D3</a>	<a href="#">D2</a>	<a href="#">D1</a>	<a href="#">D0</a>
5Dh	<a href="#">RHDLC2</a>	N/A	N/A	N/A	N/A	<a href="#">PS1</a>	<a href="#">PS0</a>	<a href="#">CBYTE</a>	<a href="#">OBYTE</a>
5Eh	<a href="#">THDLC1</a>	D7	D6	D5	D4	D3	D2	D1	D0
5Fh	<a href="#">THDLC2</a>	N/A	N/A	N/A	N/A	N/A	N/A	N/A	TMEND

Register Name: **HCR1**  
 Register Description: **HDLC Control Register 1**  
 Register Address: **50h**

Bit #	7	6	5	4	3	2	1	0
Name	RHR	THR	RID	TID	TFS	TZSD	TCRCI	TCRCD
Default	0	0	0	0	0	0	0	0

**Bit 0: Transmit CRC Defeat (TCRCD).** When this bit is logic 0, the transmit HDLC controller automatically calculates and appends the 16-bit CRC to the outgoing HDLC message. When this bit is logic 1, the transmit HDLC controller does not append the CRC to the outgoing message.

- 0 = enable CRC generation (normal operation)
- 1 = disable CRC generation

**Bit 1: Transmit CRC Invert (TCRCI).** When this bit is logic 0, the transmit HDLC controller generates the CRC normally. When this bit is logic 1, the transmit HDLC controller inverts all 16 bits of the generated CRC. This bit is ignored when CRC generation is disabled (TCRCD = 1). This bit is useful in testing HDLC operation.

- 0 = do not invert the generated CRC (normal operation)
- 1 = invert the generated CRC

**Bit 2: Transmit Zero Stuffer Defeat (TZSD).** When this bit is logic 0, the transmit HDLC controller performs zero stuffing on all data between the opening and closing flags of the HDLC message. When this bit is logic 1, the transmit HDLC controller does not perform zero stuffing.

- 0 = enable zero stuffing (normal operation)
- 1 = disable zero stuffing

**Bit 3: Transmit Flag/Idle Select (TFS).** This control bit determines whether flags or idle bytes are transmitted between packets.

- 0 = 7Eh (flags)
- 1 = FFh (idle)

**Bit 4: Transmit Invert Data (TID).** When this bit is logic 1, the entire transmit HDLC data stream (including flags and CRC checksum) is inverted before being transmitted by the DS3/E3 formatter.

- 0 = do not invert transmit HDLC data stream (normal operation)
- 1 = invert transmit HDLC data stream

**Bit 5: Receive Invert Data (RID).** When this bit is logic 1, the entire receive HDLC data stream (including flags and CRC checksum) is inverted before processing by the receive HDLC controller.

- 0 = do not invert receive HDLC data stream (normal operation)
- 1 = invert receive HDLC data stream

**Bit 6: Transmit HDLC Reset (THR).** A 0-to-1 transition resets the transmit HDLC controller. A reset flushes the transmit FIFO and causes the transmit HDLC controller to transmit one FEh abort sequence (seven 1s in a row) followed by continuous transmission of either 7Eh (flags) or FFh (idle) until the beginning of a new packet (at least two bytes) is written into the transmit HDLC FIFO.

**Bit 7: Receive HDLC Reset (RHR).** A 0-to-1 transition resets the receive HDLC controller. A reset flushes the current contents of the receive FIFO and causes the receive HDLC controller to begin searching for a new incoming HDLC packet.



Register Name: **HCR2**  
 Register Description: **HDLC Control Register 2**  
 Register Address: **51h**

Bit #	7	6	5	4	3	2	1	0
Name	N/A	RHWMS2	RHWMS1	RHWMS0	N/A	TLWMS2	TLWMS1	TLWMS0
Default	—	0	0	0	—	0	0	0

**Bits 2 to 0: Transmit Low Watermark Select Bits (TLWMS[2:0]).** These control bits determine when the HDLC controller should set the TLWM status bit in the [HSR](#) register. When the transmit FIFO contains less than the number of bytes specified by these bits, the TLWM status bit is set to logic 1.

TLWMS[2:0]	TRANSMIT LOW WATERMARK (BYTES)
000	16
001	48
010	80
011	112
100	144
101	176
110	208
111	240

**Bits 4 to 6: Receive High Watermark Select Bits (RHWMS[2:0]).** These control bits determine when the HDLC controller should set the RHWM status bit in the [HSR](#) register. When the receive FIFO contains more than the number of bytes specified by these bits, the RHWM status bit is set to logic 1.

RHWMS[2:0]	RECEIVE HIGH WATERMARK (BYTES)
000	16
001	48
010	80
011	112
100	144
101	176
110	208
111	240

Register Name: **HSR**  
 Register Description: **HDLC Status Register**  
 Register Address: **54h**

Bit #	7	6	5	4	3	2	1	0
Name	N/A	N/A	N/A	N/A	RHWM	TLWM	N/A	N/A
Default	—	—	—	—	—	—	—	—

**Bit 2: Transmit FIFO Low Watermark (TLWM).** This real-time status bit is set to a 1 when the transmit FIFO contains less than the number of bytes configured by TLWMS[2:0] control bits in the [HCR2](#) register. This bit is cleared when the FIFO fills beyond the low watermark.

**Bit 3: Receive FIFO High Watermark (RHWM).** This real-time status bit is set to a 1 when the receive FIFO contains more than the number of bytes configured by the RHWMS[2:0] control bits in the [HCR2](#) register. This bit is cleared when the FIFO empties below the high watermark.

Register Name: **HSRL**  
 Register Description: **HDLC Status Register Latched**  
 Register Address: **55h**

Bit #	7	6	5	4	3	2	1	0
Name	ROVRL	RPEL	RPSL	RABTL	RHWML	TLWML	TUDRL	TENDL
Default	—	—	—	—	—	—	—	—

**Note:** See [Figure 7-7](#) for details on the interrupt signal flow for the status bits in the HSRL register.

**Bit 0: Transmit Packet-End Latched (TENDL).** This latched status bit is set to 1 each time the transmit HDLC controller reads a transmit FIFO byte with the corresponding TMEND bit set or when a FIFO underrun occurs. TENDL is cleared when the host processor writes a 1 to it. When TENDL is set, it can cause a hardware interrupt to occur if the TENDIE bit in the [HSRIE](#) register and the HDLCIE bit in the [MSRIE](#) register are both set to 1. The interrupt is cleared when this bit is cleared or one or both of the interrupt-enable bits are cleared.

**Bit 1: Transmit FIFO Underrun Latched (TUDRL).** This latched status bit is set to 1 each time the transmit FIFO underruns. TUDRL is cleared when the host processor writes a 1 to it and is not set again until another underrun occurs (i.e., the FIFO has been written to and then allowed to empty again without the TMEND bit set). When TUDRL is set, it can cause a hardware interrupt to occur if the TUDRIE bit in the [HSRIE](#) register and the HDLCIE bit in the [MSRIE](#) register are both set to 1. The interrupt is cleared when this bit is cleared or one or both of the interrupt-enable bits are cleared.

**Bit 2: Transmit FIFO Low Watermark Latched (TLWML).** This latched status bit is set to 1 when the TLWM status bit in the [HSR](#) register goes high. TLWML is cleared when the host processor writes a 1 to it and is not set again until TLWM goes high again. When TLWML is set, it can cause a hardware interrupt to occur if the TLWMLIE bit in the [HSRIE](#) register and the HDLCIE bit in the [MSRIE](#) register are both set to one. The interrupt is cleared when this bit is cleared or one or both of the interrupt-enable bits are cleared.

**Bit 3: Receive FIFO High Watermark Latched (RHWML).** This latched status bit is set to 1 when the RHWML status bit in the [HSR](#) register goes high. RHWML is cleared when the host processor writes a one to it and is not set again until RHWML goes high again. When RHWML is set, it can cause a hardware interrupt to occur if the RHWMLIE bit in the [HSRIE](#) register and the HDLCIE bit in the [MSRIE](#) register are both set to 1. The interrupt is cleared when this bit is cleared or one or both of the interrupt-enable bits are cleared.

**Bit 4: Receive Abort Sequence Detected Latched (RABTL).** This latched status bit is set to 1 each time the receive HDLC controller detects an abort sequence (seven or more 1s in a row) during packet reception. If the receive HDLC is not currently receiving a packet, then receiving an abort sequence does not set this status bit. RABTL is cleared when the host processor writes a 1 to it and is not set again until another abort is detected (at least one valid flag must be detected before another abort can be detected). When RABTL is set, it can cause a hardware interrupt to occur if the RABTIE bit in the [HSRIE](#) register and the HDLCIE bit in the [MSRIE](#) register are both set to 1. The interrupt is cleared when this bit is cleared or one or both of the interrupt-enable bits are cleared.

**Bit 5: Receive Packet-Start Latched (RPSL).** This latched status bit is set to 1 each time the receive HDLC controller detects the start of an HDLC packet. RPSL is cleared when the host processor writes a 1 to it and is not set again until another start of packet is detected. When RPSL is set, it can cause a hardware interrupt to occur if the RPSIE bit in the [HSRIE](#) register and the HDLCIE bit in the [MSRIE](#) register are both set to 1. The interrupt is cleared when this bit is cleared or one or both of the interrupt-enable bits are cleared.

**Bit 6: Receive Packet-End Latched (RPEL).** This latched status bit is set to 1 each time the HDLC controller detects a closing flag during reception of a packet, regardless of whether the packet is valid (CRC correct) or not (bad CRC, abort sequence detected, packet too small, not an integral number of octets, or an overrun occurred). RPEL is cleared when the host processor writes a 1 to it and is not set again until another message end is detected. When RPEL is set, it can cause a hardware interrupt to occur if the RPEIE bit in the [HSRIE](#) register and the HDLCIE bit in the [MSRIE](#) register are both set to 1. The interrupt is cleared when this bit is cleared or one or both of the interrupt-enable bits are cleared.

**Bit 7: Receive FIFO Overrun Latched (ROVRL).** This latched status bit is set to 1 each time the receive FIFO overruns. ROVRL is cleared when the host processor writes a 1 to it and is not set again until another overrun occurs (i.e., the FIFO has been read from and then allowed to fill up again). When ROVRL is set, it can cause a hardware interrupt to occur if the ROVRIE bit in the [HSRIE](#) register and the HDLCIE bit in the [MSRIE](#) register are both set to 1. The interrupt is cleared when this bit is cleared or one or both of the interrupt-enable bits are cleared.

Register Name: **HSRIE**  
 Register Description: **HDLC Status Register Interrupt Enable**  
 Register Address: **56h**

Bit #	7	6	5	4	3	2	1	0
Name	ROVRIE	RPEIE	RPSIE	RABTIE	RHWMIE	TLWMIE	TUDRIE	TENDIE
Default	0	0	0	0	0	0	0	0

**Bit 0: Transmit Packet-End Interrupt Enable (TENDIE).** This bit enables an interrupt if the TENDL bit in the [HSRL](#) register is set.

- 0 = interrupt disabled
- 1 = interrupt enabled

**Bit 1: Transmit FIFO Underrun Interrupt Enable (TUDRIE).** This bit enables an interrupt if the TUDRL bit in the [HSRL](#) register is set.

- 0 = interrupt disabled
- 1 = interrupt enabled

**Bit 2: Transmit FIFO Low Watermark Interrupt Enable (TLWMIE).** This bit enables an interrupt if the TLWML bit in the [HSRL](#) register is set.

- 0 = interrupt disabled
- 1 = interrupt enabled

**Bit 3: Receive FIFO High Watermark Interrupt Enable (RHWMIE).** This bit enables an interrupt if the RHWML bit in the [HSRL](#) register is set.

- 0 = interrupt disabled
- 1 = interrupt enabled

**Bit 4: Receive Abort Sequence Detected Interrupt Enable (RABTIE).** This bit enables an interrupt if the RABTL bit in the [HSRL](#) register is set.

- 0 = interrupt disabled
- 1 = interrupt enabled

**Bit 5: Receive Packet Start Interrupt Enable (RPSIE).** This bit enables an interrupt if the RPSL bit in the [HSRL](#) register is set.

- 0 = interrupt disabled
- 1 = interrupt enabled

**Bit 6: Receive Packet-End Interrupt Enable (RPEIE).** This bit enables an interrupt if the RPEL bit in the [HSRL](#) register is set.

- 0 = interrupt disabled
- 1 = interrupt enabled

**Bit 7: Receive FIFO Overrun Interrupt Enable (ROVRIE).** This bit enables an interrupt if the ROVRL bit in the [HSRL](#) register is set.

- 0 = interrupt disabled
- 1 = interrupt enabled

Figure 7-7. HDLC Status Bit Interrupt Signal Flow

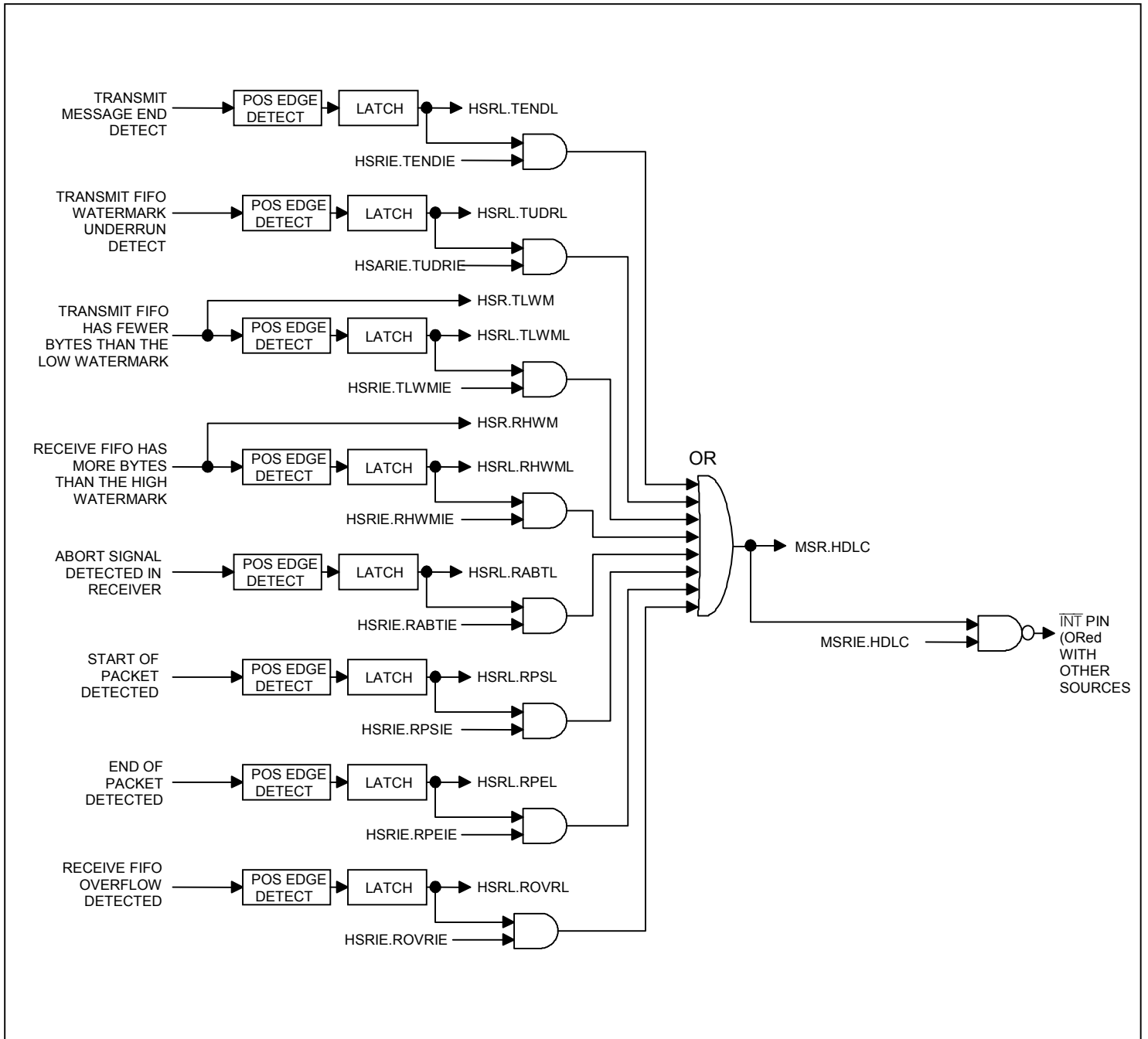

Register Name: **HIR**  
 Register Description: **HDLC Information Register**  
 Register Address: **57h**

Bit #	7	6	5	4	3	2	1	0
Name	N/A	N/A	<u>EMPTY</u>	<u>EMPTY</u>	<u>TFL3</u>	<u>TFL2</u>	<u>TFL1</u>	<u>TFL0</u>
Default	—	—	—	—	—	—	—	—

**Note:** Bits in this information register cannot cause an interrupt to occur.

**Bits 0 to 3: Transmit FIFO Level (TFL[3:0]).** These real-time status bits indicate the current depth of the transmit FIFO in 16-byte increments.

TFL3	TFL2	TFL1	TFL0	TRANSMIT FIFO LEVEL (BYTES)
0	0	0	0	Empty to 15
0	0	0	1	16 to 31
0	0	1	0	32 to 47
0	0	1	1	48 to 63
0	1	0	0	64 to 79
0	1	0	1	80 to 95
0	1	1	0	96 to 111
0	1	1	1	112 to 127
1	0	0	0	128 to 143
1	0	0	1	144 to 159
1	0	1	0	160 to 175
1	0	1	1	176 to 191
1	1	0	0	192 to 207
1	1	0	1	208 to 223
1	1	1	0	224 to 239
1	1	1	1	240 to 256

**Bit 4: Transmit FIFO Empty (EMPTY).** This real-time status bit is set when the transmit FIFO is empty and cleared when the transmit FIFO contains one or more bytes.

**Bit 5: Receive FIFO Empty (EMPTY).** This real-time status bit is set when the receive FIFO is empty and cleared when the receive FIFO contains one or more bytes.

Register Name: **RHDLC1**  
 Register Description: **Receive HDLC FIFO Data**  
 Register Address: **5Ch**

Bit #	7	6	5	4	3	2	1	0
Name	<u>D7</u>	<u>D6</u>	<u>D5</u>	<u>D4</u>	<u>D3</u>	<u>D2</u>	<u>D1</u>	<u>D0</u>
Default	—	—	—	—	—	—	—	—

**Note:** After the RHDLC2 register is read, the receive FIFO read pointer advances and both the RHDLC1 and RHDLC2 registers are updated with the next data/status from the receive FIFO. The host processor should read RHDLC1 first to retrieve the FIFO data and then immediately read RHDLC2 to retrieve the associated FIFO status bits.

**Bits 0 to 7: Receive FIFO Data (D[7:0]).** These bits contain the next byte of receive FIFO data. D0 is the LSB and is the first bit received by the framer, while D7 is the MSB and is the last bit received. Reading this register does not cause the receive FIFO read pointer to advance.

Register Name: **RHDLC2**  
 Register Description: **Receive HDLC FIFO Status**  
 Register Address: **5Dh**

Bit #	7	6	5	4	3	2	1	0
Name	N/A	N/A	N/A	N/A	<u>PS1</u>	<u>PS0</u>	<u>CBYTE</u>	<u>OBYTE</u>
Default	—	—	—	—	—	—	—	—

**Bit 0: Opening Byte Indicator (OBYTE).** This bit is set to 1 when the RHDLC1 register contains the first byte of an HDLC packet.

**Bit 1: Closing Byte Indicator (CBYTE).** This bit is set to 1 when the RHDLC1 register contains the last byte of an HDLC packet, whether the packet is valid or not. The host processor can check the PS[1:0] bits to determine packet validity.

**Bits 2, 3: Packet Status (PS[1:0]).** These bits are only valid when the CBYTE bit is set to 1. These bits indicate the validity of the incoming packet and the cause of the problem if the packet was received in error.

PS[1:0]	PACKET STATUS	REASON FOR INVALID RECEPTION OF THE PACKET
00	Valid	—
01	Invalid	Corrupt CRC
10	Invalid	Incoming packet was either too short (less than 4 bytes including the CRC) or did not contain an integral number of octets
11	Invalid	Abort sequence detected

Packets fewer than four bytes long (including the FCS) are invalid and the data that appears in the FIFO in such instances is meaningless. If only one byte is received between flags, then both the CBYTE and OBYTE bits are set. If two bytes are received, then OBYTE is set for the first byte received and CBYTE is set for the second byte received. If three bytes are received, then OBYTE is set for the first byte received and CBYTE is set for the third byte received. In all of these cases, the packet status is reported as PS[1:0] = 10, and the data in the FIFO should be ignored.

Register Name: **THDLC1**  
 Register Description: **Transmit HDLC FIFO Data**  
 Register Address: **5Eh**

Bit #	7	6	5	4	3	2	1	0
Name	D7	D6	D5	D4	D3	D2	D1	D0
Default	0	0	0	0	0	0	0	0

**Note 1:** The host processor should always write to THDLC1 first followed by THDLC2. Writing to THDLC2 latches the data from both THDLC1 and THDLC2 into the transmit FIFO.

**Note 2:** THDLC1 and THDLC2 are write-only registers. Data read from these registers is undefined.

**Note 3:** The transmit FIFO can be filled to a maximum capacity of 256 bytes. When the transmit FIFO is full, it does not latch additional data.

**Bits 0 to 7: Transmit FIFO Data (D[7:0]).** Data for the transmit FIFO is written to these bits. D0 is the LSB and is transmitted first, while D7 is the MSB and is transmitted last.

Register Name: **THDLC2**  
 Register Description: **Transmit HDLC FIFO Status**  
 Register Address: **5Fh**

Bit #	7	6	5	4	3	2	1	0
Name	N/A	N/A	N/A	N/A	N/A	N/A	N/A	TMEND
Default	—	—	—	—	—	—	—	0

**Bit 0: Transmit Message End (TMEND).** This bit is used to delineate packets in the transmit FIFO. It should be set to 1 when the last byte of a message is written to the THDLC1 register. When set to 1, TMEND indicates that the message is complete and that the HDLC controller should calculate and append the CRC checksum (FCS) and at least two flags (7Eh). This bit should be set to 0 for all other data written to the FIFO. All outgoing HDLC messages must be at least two bytes in length.

## 7.11 FEAC Controller

The DS3 C-Bit Parity far-end alarm and control (FEAC) channel carries repeating 16-bit codewords of the form 0xxxxx01111111 (rightmost bit transmitted first), where x can be 0 or 1. These codewords are used to send alarm or status information from the far end to the near end, and send loopback commands to the far end.

Each DS314x framer contains an on-board FEAC controller. When the framer is in DS3 C-Bit Parity mode, the FEAC controller sources and sinks the FEAC channel (the third C-bit in M-subframe 1). When the framer is in E3 mode, the FEAC receiver is always connected to the E3 national bit (Sn, bit 12 of the E3 frame). If the host processor does not wish to use the FEAC controller for processing the E3 national bit, then it should ignore the status provided by the FEAC receiver. The FEAC transmitter can be provisioned to source the E3 national bit by setting [T3E3CR1](#):E3SnC[1:0] = 10. The FEAC controller is not used in DS3 M23 framing mode.

The FEAC transmitter can be configured to transmit one codeword 10 times, one codeword continuously, or one codeword 10 times followed by another codeword 10 times. This last option is useful for sending loopback commands where the loopback activate/deactivate command must be followed by the code for line to be looped back. FEAC codewords are transmitted at least 10 times. When the FEAC transmitter is not sending codewords, it enters the idle state where it transmits all ones on the FEAC channel and sets the transmit FEAC idle bit ([FSR](#):TFI) to 1.

The FEAC receiver does a bit-by-bit search for a data pattern matching the form of a FEAC codeword. When a codeword is found, the receiver validates the codeword by checking to see that the same codeword is found in three consecutive opportunities. After a codeword is validated, the receiver sets the receive FEAC codeword detect status bit ([FSR](#):RFCD) and writes the codeword into the receive FEAC FIFO for the host processor to read. The host processor can use the RFCD or receive FEAC FIFO empty (RFFE) status bits to know when to read the receive FEAC FIFO. The receive FEAC FIFO is four codewords deep. If the FIFO is full when the FEAC receiver attempts to write a new codeword, the new codeword is discarded and the receive FEAC FIFO Overflow status bit (RFFOL) is set. The FEAC receiver clears the RFCD status bit when the valid codeword is no longer present on the FEAC channel (i.e., when a different codeword is received twice in a row).

**Table 7-1. FEAC Register Map**

ADDR	REGISTER	BIT 7	BIT 6	BIT 5	BIT 4	BIT 3	BIT 2	BIT 1	BIT 0
60h	<a href="#">FCR</a>	N/A	N/A	N/A	N/A	N/A	RFR	TFS1	TFS0
61h	<a href="#">FSR</a>	N/A	N/A	N/A	N/A	<a href="#">RFFE</a>	<a href="#">RFI</a>	<a href="#">RFCD</a>	<a href="#">TFI</a>
62h	<a href="#">FSRL</a>	N/A	N/A	N/A	RFFOL	RFFNL	RFIL	RFCDL	TFIL
63h	<a href="#">FSRIE</a>	N/A	N/A	N/A	RFFOIE	RFFNIE	RFIIE	RFCDIE	TFIIE
64h	<a href="#">TFEACA</a>	N/A	N/A	TFCA5	TFCA4	TFCA3	TFCA2	TFCA1	TFCA0
65h	<a href="#">TFEACB</a>	N/A	N/A	TFCB5	TFCB4	TFCB3	TFCB2	TFCB1	TFCB0
66h	<a href="#">RFEAC</a>	N/A	N/A	<a href="#">RFF5</a>	<a href="#">RFF4</a>	<a href="#">RFF3</a>	<a href="#">RFF2</a>	<a href="#">RFF1</a>	<a href="#">RFF0</a>

Register Name: **FCR**  
Register Description: **FEAC Control Register**  
Register Address: **60h**

Bit #	7	6	5	4	3	2	1	0
Name	N/A	N/A	N/A	N/A	N/A	RFR	TFS1	TFS0
Default	—	—	—	—	—	0	0	0

**Bits 0, 1: Transmit FEAC Codeword Select Bits 0 and 1 (TFS[1:0]).** These two bits control which of the two available codewords are to be generated. Both TFS0 and TFS1 are edge-triggered; a change from 00 to any other value starts the desired FEAC transmission. Actions 01 and 10 continue to completion even if TFS is subsequently written with 00. Action 11 transmits at least 10 codewords before being terminated by TFS = 00. To initiate a new action, the host must select the idle state (TFS = 00) before selecting the new action.

TFS[1:0]	ACTION
00	Idle state; do not generate a FEAC codeword (send all ones)
01	Send codeword A 10 times followed by all ones
10	Send codeword A 10 times followed codeword B 10 times followed by all ones
11	Send codeword A continuously (sent at least 10 times)

**Bit 2: Receive FEAC Reset (RFR).** A 0-to-1 transition resets the FEAC receiver and flushes the receive FEAC FIFO. This bit must be cleared before generating a subsequent reset.

Register Name: **FSR**  
Register Description: **FEAC Status Register**  
Register Address: **61h**

Bit #	7	6	5	4	3	2	1	0
Name	N/A	N/A	N/A	N/A	<a href="#">RFFE</a>	<a href="#">RFI</a>	<a href="#">RFCD</a>	<a href="#">TFI</a>
Default	—	—	—	—	—	—	—	—

**Bit 0: Transmit FEAC Idle (TFI).** This real-time status bit is set when the FEAC transmitter is sending the all-ones idle code. It is cleared when the FEAC transmitter is sending a FEAC codeword.

**Bit 1: Receive FEAC Codeword Detected (RFCD).** This real-time status bit is set each time the FEAC receiver has detected and validated a new FEAC codeword. It is cleared when the validated codeword is no longer present on the FEAC channel.

**Bit 2: Receive FEAC Idle (RFI).** This real-time status bit is set when the FEAC controller has detected 16 consecutive 1s. It is cleared when the FEAC receiver has detected and validated a new FEAC codeword.

**Bit 3: Receive FEAC FIFO Empty (RFFE).** This real-time status bit is set when the receive FEAC FIFO is empty, and thus RFF[5:0] contains no valid information. It is cleared when the receive FIFO contains one or more codewords.



Register Name: **FSRL**  
 Register Description: **FEAC Status Register Latched**  
 Register Address: **62h**

Bit #	7	6	5	4	3	2	1	0
Name	N/A	N/A	N/A	RFFOL	RFFNL	RFIL	RFCDL	TFIL
Default	—	—	—	—	—	—	—	—

**Note:** See [Figure 7-8](#) for details on the interrupt logic for the status bits in the BSRL register.

**Bit 0: Transmit FEAC Idle Latched (TFIL).** This latched status bit is set to 1 when the TFI status bit in the [FSR](#) register goes high. TFIL is cleared when the host processor writes a 1 to it and is not set again until TFI goes high again. When TFIL is set, it can cause a hardware interrupt to occur if the TFIIE bit in the [FSRIE](#) register and the FEACIE bit in the [MSRIE](#) register are both set. The interrupt is cleared when this bit is cleared or one or both of the interrupt-enable bits are cleared. This bit can be used to determine when the FEAC codeword transmission has finished, and thus a new codeword can be transmitted.

**Bit 1: Receive FEAC Codeword Detected Latched (RFCDL).** This latched status bit is set to 1 when the RFCD status bit in the [FSR](#) register goes high. RFCDL is cleared when the host processor writes a one to it and is not set again until RFCD goes high again. When RFCDL is set, it can cause a hardware interrupt to occur if the RFCDIE bit in the [FSRIE](#) register and the FEACIE bit in the [MSRIE](#) register are both set. The interrupt is cleared when this bit is cleared or one or both of the interrupt-enable bits are cleared.

**Bit 2: Receive FEAC Idle Latched (RFIL).** This latched status bit is set to 1 when the RFI status bit in the [FSR](#) register goes high. RFIL is cleared when the host processor writes a 1 to it and is not set again until RFI goes high again. When RFIL is set, it can cause a hardware interrupt to occur if the RFIIE bit in the [FSRIE](#) register and the FEACIE bit in the [MSRIE](#) register are both set. The interrupt is cleared when this bit is cleared or one or both of the interrupt-enable bits are cleared. This bit can be used to determine when the FEAC receiver has stopped receiving codewords, which can mark the end of an alarm situation.

**Bit 3: Receive FEAC FIFO Not-Empty Latched (RFFNL).** This latched status bit is set to 1 when the RFFE bit in the [FSR](#) register goes low. RFFNL is cleared when the host processor writes a 1 to it and is not set again until the RFFE bit goes low again. When RFFNL is set, it can cause a hardware interrupt to occur if the RFFNIE bit in the [FSRIE](#) register and the FEACIE bit in the [MSRIE](#) register are both set. The interrupt is cleared when this bit is cleared or one or both of the interrupt-enable bits are cleared. This bit can be used to determine when to read FEAC codeword(s) from the FIFO.

**Bit 4: Receive FEAC FIFO Overflow Latched (RFFOL).** This latched status bit is set to 1 when the receive FEAC controller has attempted to write to an already full receive FEAC FIFO and the current incoming FEAC codeword is lost. RFFOL is cleared when the host processor writes a 1 to it and is not set again until another FIFO overflow occurs (i.e., the receive FEAC FIFO has been read and then fills beyond capacity). When RFFOL is set, it can cause a hardware interrupt to occur if the RFFOIE bit in the [FSRIE](#) register and the FEACIE bit in the [MSRIE](#) register are both set. The interrupt is cleared when this bit is cleared or one or both of the interrupt-enable bits are cleared.

Register Name: **FSRIE**  
 Register Description: **FEAC Status Register Interrupt Enable**  
 Register Address: **63h**

Bit #	7	6	5	4	3	2	1	0
Name	N/A	N/A	N/A	RFFOIE	RFFNIE	RFIIE	RFCDIE	TFIIE
Default	—	—	—	0	0	0	0	0

**Bit 0: Transmit FEAC Idle Interrupt Enable (TFIIE).** This bit enables an interrupt if the TFIL bit in the [FSRL](#) register is set.

- 0 = interrupt disabled
- 1 = interrupt enabled

**Bit 1: Receive FEAC Codeword Detected Interrupt Enable (RFCDIE).** This bit enables an interrupt if the RFCDL bit in the [FSRL](#) register is set.

- 0 = interrupt disabled
- 1 = interrupt enabled

**Bit 2: Receive FEAC Idle Interrupt Enable (RFIIE).** This bit enables an interrupt if the RFIL bit in the [FSRL](#) register is set.

- 0 = interrupt disabled
- 1 = interrupt enabled

**Bit 3: Receive FEAC FIFO Not-Empty Interrupt Enable (RFFNIE).** This bit enables an interrupt if the RFFNL bit in the [FSRL](#) register is set.

- 0 = interrupt disabled
- 1 = interrupt enabled

**Bit 4: Receive FEAC FIFO Overflow Interrupt Enable (RFFOIE).** This bit enables an interrupt if the RFFOL bit in the [FSRL](#) register is set.

- 0 = interrupt disabled
- 1 = interrupt enabled

**Figure 7-8. FEAC Status Bit Interrupt Signal Flow**

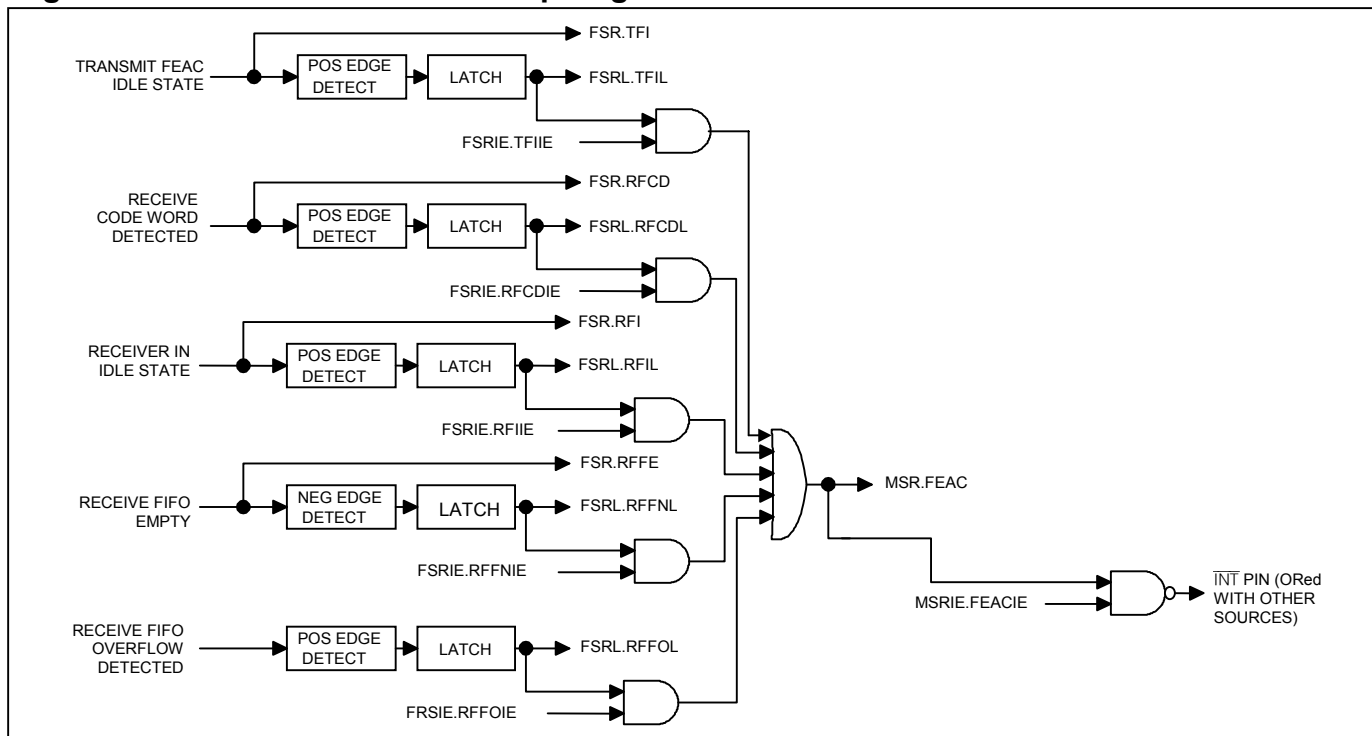

Register Name: **TFEACA**  
 Register Description: **Transmit FEAC A**  
 Register Address: **64h**

Bit #	7	6	5	4	3	2	1	0
Name	N/A	N/A	TFCA5	TFCA4	TFCA3	TFCA2	TFCA1	TFCA0
Default	—	—	0	0	0	0	0	0

**Bits 0 to 5: Transmit FEAC Codeword A Data (TFCA[5:0]).** The FEAC codeword is of the form ...0xxxxxx01111111... where the rightmost bit is transmitted first. TFCA[5:0] are the middle six bits of the second byte of the FEAC codeword (i.e., the six “x” bits). The transmit FEAC controller can generate two different codewords. These six bits specify what is to be transmitted for codeword A. TFCA0 is the LSB and is transmitted first; TFCA5 is the MSB and is transmitted last. The TFS[1:0] control bits determine if this codeword is to be transmitted. These bits should only be changed when the transmit FEAC controller is in the idle state (TFS[1:0] = 00).

Register Name: **TFEACB**  
 Register Description: **Transmit FEAC B**  
 Register Address: **65h**

Bit #	7	6	5	4	3	2	1	0
Name	N/A	N/A	TFCB5	TFCB4	TFCB3	TFCB2	TFCB1	TFCB0
Default	—	—	0	0	0	0	0	0

**Bits 0 to 5: Transmit FEAC Codeword B Data (TFCB[5:0]).** The FEAC codeword is of the form ...0xxxxxx01111111... where the right-most bit is transmitted first. TFCB[5:0] are the middle six bits of the second byte of the FEAC codeword (i.e., the six “x” bits). The transmit FEAC controller can generate two different codewords. These six bits specify what is to be transmitted for codeword B. TFCB0 is the LSB and is transmitted first; TFCB5 is the MSB and is transmitted last. The TFS[1:0] control bits determine if this codeword is to be transmitted. These bits should only be changed when the transmit FEAC controller is in the idle state (TFS[1:0] = 00).

Register Name: **RFEAC**  
 Register Description: **Receive FEAC**  
 Register Address: **66h**

Bit #	7	6	5	4	3	2	1	0
Name	N/A	N/A	<u>RFF5</u>	<u>RFF4</u>	<u>RFF3</u>	<u>RFF2</u>	<u>RFF1</u>	<u>RFF0</u>
Default	—	—	—	—	—	—	—	—

**Bits 0 to 5: Receive FEAC FIFO Data (RFF[5:0]).** Data from the receive FEAC FIFO can be read from these bits. The FEAC codeword is of the form ...0xxxxxx01111111... where the right-most bit is received first. These six bits are the debounced and integrated middle six bits of the second byte of the FEAC codeword (i.e., the six “x” bits). RFF0 is the LSB and is received first; RFF5 is the MSB and is received last.

## 8. OPERATION DETAILS

### 8.1 Reset

The DS314x devices must be reset by activating the  $\overline{JTRST}$  and  $\overline{RST}$  pins after the power supply has settled and the input clocks have stabilized to their normal operating conditions. The  $\overline{JTRST}$  pin can be permanently wired low if desired. After reset, all read/write control register bits are reset to 0 except for RDATH and TUA1, which are set to 1. The reset states of the device pins are as follows:

- E3 mode is enabled.
- The LIU interface is in dual-rail (POS/NEG) mode with HDB3 encoding and decoding enabled.
- TPOS and TNEG transmit an unframed all-ones signal (E3 AIS) on the transmit LIU interface.
- RDAT is forced to a logic 1 level to present an unframed all-ones signal (E3 AIS) on the receive system interface.
- TCLK is a noninverted, delayed version of TCLK.
- ROCLK is a noninverted, delayed version or RCLK.
- TSOF is an active-high input pin.
- RSOF, RLOS, and ROOF are active high.
- TDEN/TGCLK is in the TDEN (data enable) mode and is active high.
- RDEN/RGCLK is in the RDEN (data enable) mode and is active high.
- JTDO is tri-stated.

### 8.2 DS3 and E3 Mode Configuration

In all modes, the TUA1 bit in the [MC1](#) register and RDATH bit in the [MC4](#) register must be cleared. These bits are set to 1 at reset to generate an unframed all-ones (E3 AIS) signal on both the transmit LIU interface (TPOS/TNEG) and the receive system interface (RDAT).

#### E3 Mode

Default framer operation after reset is E3 mode. To begin operation in E3 mode after reset, clear the TUA1 bit in the [MC1](#) register and clear the RDATH bit in the [MC4](#) register. A 34.368MHz clock must be applied to the TCLK pin.

#### DS3 M23 Mode

To change framer operation after reset to DS3 M23 mode, set the DS3M bit to 1 in the [T3E3CR1](#) register, clear the TUA1 bit in the [MC1](#) register, and clear the RDATH bit in the [MC4](#) register. A 44.736MHz clock must be applied to the TCLK pin.

#### DS3 C-Bit Parity Mode

To change framer operation after reset to DS3 C-Bit Parity mode, set the DS3M and CBEN bits to 1 in the [T3E3CR1](#) register, clear the TUA1 bit in the [MC1](#) register, and clear the RDATH bit in the [MC4](#) register. A 44.736MHz clock must be applied to the TCLK pin.

### 8.3 LIU and System Interface Configuration

#### LIU Interface

After reset the default LIU interface format is dual-rail (POS/NEG) with B3ZS/HDB3 encoding and decoding enabled. To change framer operation after reset to binary (NRZ) format with B3ZS/HDB3 encoding and decoding disabled (disabled in the framer but should be enabled in the LIU), set the BIN bit to 1 in the [MC1](#) register.

#### System Interface

After reset the TDEN/TGCLK and RDEN/RGCLK pins default to data enable behavior (TDEN, RDEN) and the TSOF pin defaults to being an input. If gapped clock behavior is desired, set the TDENMS bit in the [MC3](#) register and/or the RDENMS bit in the [MC4](#) register. To configure TSOF as an output pin, set the TSOF bit to 1 in the [MC3](#) register.

## 8.4 Loopback Modes

The loopback modes are selected by setting the LLB, DLB, and/or PLB bits in the [MC2](#) register. See [Figure 1-1](#) for a visual description of these loopbacks. At reset, none of the loopback modes are activated. PLB and DLB may not be active at the same time. If LLB and PLB are both active at the same time, then TPOS/TRNZ, TNEG, and TCLK are sourced from RPOS/RNRZ, RNEG/RLCV, and RCLK while the internal workings of the framer are in PLB mode.

The line loopback (LLB) mode is used to send the received signal back toward the network. TAIS and TUA1 are not available during line loopback, but the TPOS/TRNZ and TNEG pins can be forced high and low using the TPOSH, TPOSI, TNEGH, and TNEGI bits in the [MC5](#) register.

The diagnostic loopback (DLB) mode is used to send the transmitted signal back toward the system through the receive framer. When the framer is in diagnostic loopback, it can simultaneously transmit AIS to the far end if the TAIS bit is set in the [T3E3CR1](#) register. The framer supports simultaneous line loopback and diagnostic loopback.

The payload loopback (PLB) mode is used to send the received payload back toward the network with new overhead inserted. When the framer is in payload loopback, the internal transmit clock is connected to the internal receive clock, internal transmit data is sourced from internal receive data, and TICLK and TDAT are ignored. The TDEN and TSOF signals are aligned with the RDEN and RSOF signals, and TOH and TOHEN are still enabled. The TSOF, TDEN, TOH, and TOHEN signals are timed relative to ROCLK rather than TICLK.

## 8.5 Transmit Overhead Insertion

The transmit signal can be overwritten at any bit location using the TOH and TOHEN signals. The TSOF signal marks the start of the transmit frame and is used to determine which bits to overwrite. To overwrite a specific bit in the DS3 or E3 frame, count the required number of TICLK cycles after the TSOF frame pulse. When the proper TICLK cycle is reached, assert the TOHEN pin to replace normal transmit data (overhead or payload) with the value on the TOH pin. One application for the TOH and TOHEN pins is to use some of the unused C bits in DS3 C-Bit Parity mode for a proprietary communications channel.

During payload loopback, the transmit side is timed from ROCLK rather than TICLK. If the system needs to support transmit overhead insertion (TOH) during payload loopback (PLB), then TOH and TOHEN must also be timed with respect to ROCLK. One way to access ROCLK is to set the TCCLK bit in the [MC2](#) register to convert the TDEN/TGCLK output pin into a constant clock, which is based on ROCLK during payload loopback. TOH and TOHEN can then be timed with respect to the constant clock on the TDEN/TGCLK pin.

## 9. JTAG INFORMATION

The DS3146, DS3148, and DS31412 support the standard instruction codes SAMPLE/PRELOAD, BYPASS, and EXTEST. Optional public instructions included are HIGHZ, CLAMP, and IDCODE. See the JTAG block diagram in [Figure 9-1](#). The device contains the following items, which meet the requirements set by the IEEE 1149.1 Standard Test Access Port (TAP) and Boundary Scan Architecture:

Test Access Port (TAP)  
TAP Controller  
Instruction Register

Bypass Register  
Boundary Scan Register  
Device Identification Register

The Test Access Port has the necessary interface pins, namely JTCLK, JTDI, JTDO, and JTMS, and the optional  $\overline{\text{JTRST}}$  input. Details on these pins can be found in [Section 5.6](#). Refer to IEEE 1149.1-1990, IEEE 1149.1a-1993, and IEEE 1149.1b-1994 for details about the Boundary Scan Architecture and the Test Access Port.

**Figure 9-1. JTAG Block Diagram**

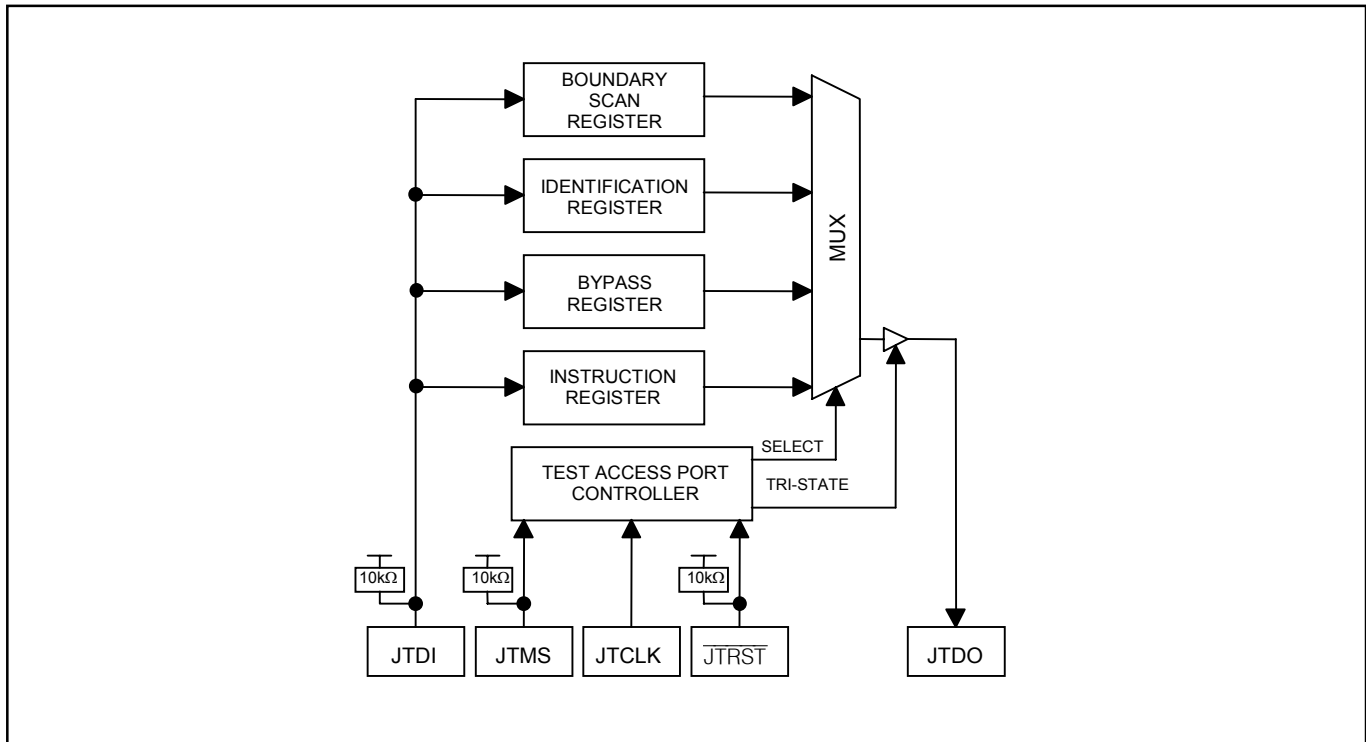

### 9.1 JTAG TAP Controller State Machine

This section covers the operation of the TAP controller state machine. See [Figure 9-2](#) for details on each of the states described below. The TAP controller is a finite state machine that responds to the logic level at JTMS on the rising edge of JTCLK.

**Test-Logic-Reset.** When  $\overline{\text{JTRST}}$  is changed from low to high, the TAP controller starts in the Test-Logic-Reset state, and the instruction register is loaded with the IDCODE instruction. All system logic and I/O pads on the device operate normally.

**Run-Test-Idle.** Run-Test-Idle is used between scan operations or during specific tests. The instruction register and test register remain idle.

Figure 9-2. JTAG TAP Controller State Machine

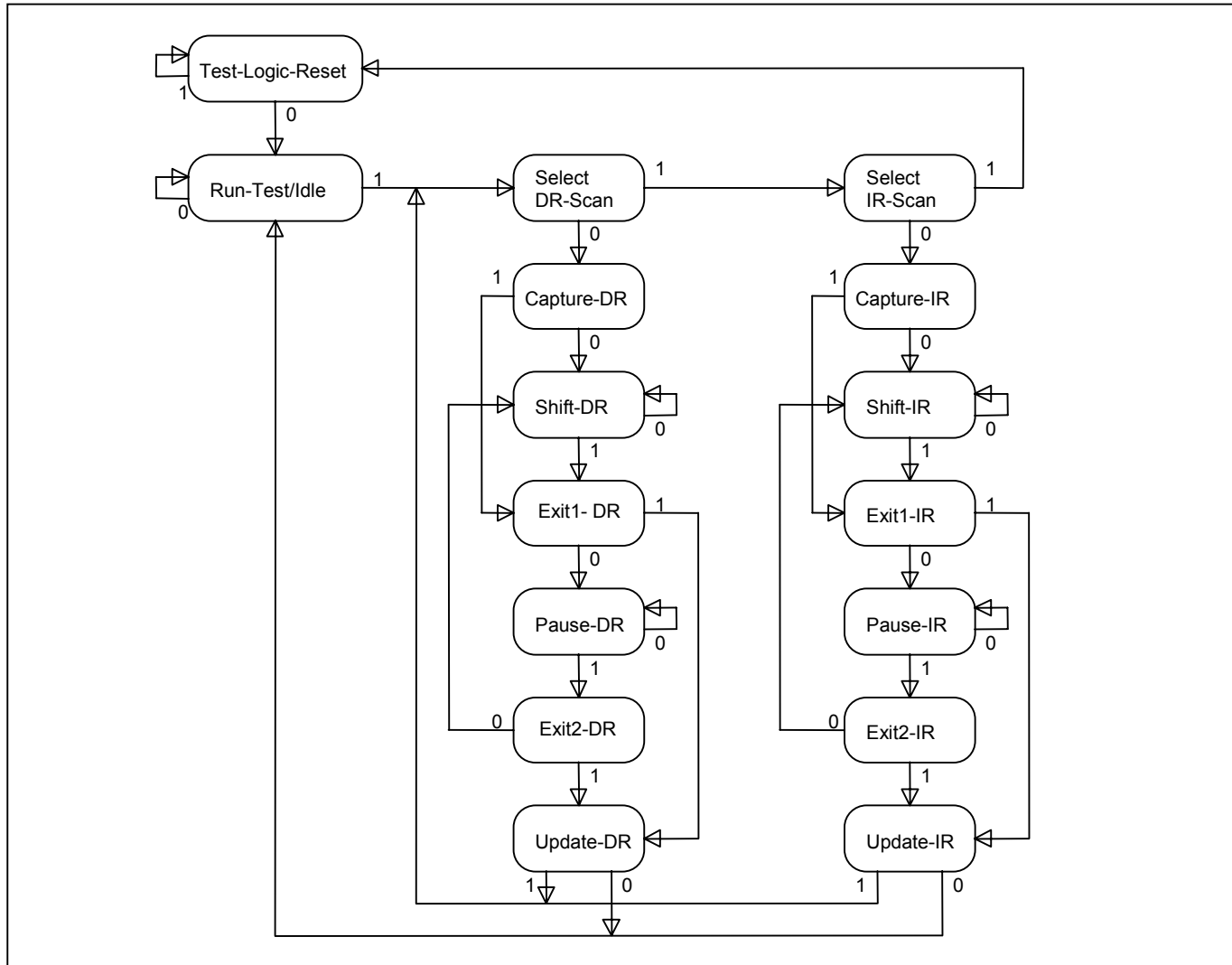

**Select-DR-Scan.** All test registers retain their previous state. With JTMS low, a rising edge of JTCLK moves the controller into the Capture-DR state and initiates a scan sequence. JTMS high moves the controller to the Select-IR-SCAN state.

**Capture-DR.** Data can be parallel loaded into the test data registers selected by the current instruction. If the instruction does not call for a parallel load or the selected register does not allow parallel loads, the test register remains at its current value. On the rising edge of JTCLK, the controller goes to the Shift-DR state if JTMS is low or to the Exit1-DR state if JTMS is high.

**Shift-DR.** The test data register selected by the current instruction is connected between JTDI and JTDO and shifts data one stage toward its serial output on each rising edge of JTCLK. If a test register selected by the current instruction is not placed in the serial path, it maintains its previous state.

**Exit1-DR.** While in this state, a rising edge on JTCLK with JTMS high puts the controller in the Update-DR state, which terminates the scanning process. A rising edge on JTCLK with JTMS low puts the controller in the Pause-DR state.

**Pause-DR.** Shifting of the test registers is halted while in this state. All test registers selected by the current instruction retain their previous state. The controller remains in this state while JTMS is low. A rising edge on JTCLK with JTMS high puts the controller in the Exit2-DR state.

**Exit2-DR.** While in this state, a rising edge on JTCLK with JTMS high puts the controller in the Update-DR state and terminates the scanning process. A rising edge on JTCLK with JTMS low puts the controller in the Shift-DR state.

**Update-DR.** A falling edge on JTCLK while in the Update-DR state latches the data from the shift register path of the test registers into the data output latches. This prevents changes at the parallel output because of changes in the shift register. A rising edge on JTCLK with JTMS low puts the controller in the Run-Test-Idle state. With JTMS high, the controller enters the Select-DR-Scan state.

**Select-IR-Scan.** All test registers retain their previous state. The instruction register remains unchanged during this state. With JTMS low, a rising edge on JTCLK moves the controller into the Capture-IR state and initiates a scan sequence for the instruction register. JTMS high during a rising edge on JTCLK puts the controller back into the Test-Logic-Reset state.

**Capture-IR.** The Capture-IR state is used to load the shift register in the instruction register with a fixed value. This value is loaded on the rising edge of JTCLK. If JTMS is high on the rising edge of JTCLK, the controller enters the Exit1-IR state. If JTMS is low on the rising edge of JTCLK, the controller enters the Shift-IR state.

**Shift-IR.** In this state, the shift register in the instruction register is connected between JTDI and JTDO and shifts data one stage for every rising edge of JTCLK toward the serial output. The parallel register and all test registers remain at their previous states. A rising edge on JTCLK with JTMS high moves the controller to the Exit1-IR state. A rising edge on JTCLK with JTMS low keeps the controller in the Shift-IR state while moving data one stage through the instruction shift register.

**Exit1-IR.** A rising edge on JTCLK with JTMS low puts the controller in the Pause-IR state. If JTMS is high on the rising edge of JTCLK, the controller enters the Update-IR state and terminates the scanning process.

**Pause-IR.** Shifting of the instruction register is halted temporarily. With JTMS high, a rising edge on JTCLK puts the controller in the Exit2-IR state. The controller remains in the Pause-IR state if JTMS is low during a rising edge on JTCLK.

**Exit2-IR.** A rising edge on JTCLK with JTMS high puts the controller in the Update-IR state. The controller loops back to the Shift-IR state if JTMS is low during a rising edge of JTCLK in this state.

**Update-IR.** The instruction shifted into the instruction shift register is latched into the parallel output on the falling edge of JTCLK as the controller enters this state. Once latched, this instruction becomes the current instruction. A rising edge on JTCLK with JTMS low puts the controller in the Run-Test-Idle state. With JTMS high, the controller enters the Select-DR-Scan state.

## 9.2 JTAG Instruction Register and Instructions

The instruction register contains a shift register as well as a latched parallel output and is 3 bits in length. When the TAP controller enters the Shift-IR state, the instruction shift register is connected between JTDI and JTDO. While in the Shift-IR state, a rising edge on JTCLK with JTMS low shifts data one stage toward the serial output at JTDO. A rising edge on JTCLK in the Exit1-IR state or the Exit2-IR state with JTMS high moves the controller to the Update-IR state. The falling edge of that same JTCLK latches the data in the instruction shift register to the instruction parallel output. [Table 9-A](#) shows the instructions supported by the device and their respective operational binary codes.

**Table 9-A. JTAG Instruction Codes**

INSTRUCTIONS	SELECTED REGISTER	INSTRUCTION CODES
SAMPLE/PRELOAD	Boundary Scan	010
BYPASS	Bypass	111
EXTEST	Boundary Scan	000
CLAMP	Bypass	011
HIGHZ	Bypass	100
IDCODE	Device Identification	001



**SAMPLE/PRELOAD.** SAMPLE/PRELOAD is a mandatory instruction for the IEEE 1149.1 specification. This instruction supports two functions. The digital I/Os of the device can be sampled at the boundary scan register without interfering with the normal operation of the device by using the Capture-DR state. SAMPLE/PRELOAD also allows the device to shift data into the boundary scan register through JTDI using the Shift-DR state.

**EXTEST.** EXTEST allows testing of all interconnections to the device. When the EXTEST instruction is latched in the instruction register, the following actions occur. Once enabled by the Update-IR state, the parallel outputs of all digital output pins are driven. The boundary scan register is connected between JTDI and JTDO. The Capture-DR samples all digital inputs into the boundary scan register.

**BYPASS.** When the BYPASS instruction is latched into the parallel instruction register, JTDI connects to JTDO through the 1-bit bypass test register. This allows data to pass from JTDI to JTDO not affecting the device's normal operation.

**IDCODE.** When the IDCODE instruction is latched into the parallel instruction register, the identification test register is selected. The device identification code is loaded into the identification register on the rising edge of JTCLK following entry into the Capture-DR state. Shift-DR can be used to shift the identification code out serially through JTDO. During Test-Logic-Reset, the identification code is forced into the instruction register's parallel output.

**HIGHZ.** All digital outputs are placed into a high-impedance state. The bypass register is connected between JTDI and JTDO.

**CLAMP.** All digital output pins output data from the boundary scan parallel output while connecting the bypass register between JTDI and JTDO. The outputs do not change during the CLAMP instruction.

**Table 9-B. JTAG ID Code**

DEVICE	REVISION	DEVICE CODE	MANUFACTURER'S CODE	REQUIRED
DS3146	Consult factory	000000000010101	00010100001	1
DS3148	Consult factory	000000000010110	00010100001	1
DS31412	Consult factory	000000000010111	00010100001	1

### 9.3 JTAG Scan Registers

IEEE 1149.1 requires a minimum of two test registers—the bypass register and the boundary scan register. An optional test register, the identification register, has been included in the design and is used with the IDCODE instruction and the Test-Logic-Reset state of the TAP controller.

#### Bypass Register

The bypass register is a single 1-bit shift register used with the BYPASS, CLAMP, and HIGHZ instructions that provides a short path between JTDI and JTDO.

#### Identification Register

The identification register contains a 32-bit shift register and a 32-bit latched parallel output. This register is selected during the IDCODE instruction and when the TAP controller is in the Test-Logic-Reset state. The device ID code always has a 1 in the LSB position. The next 11 bits identify the manufacturer's JEDEC number and number of continuation bytes, followed by 16 bits for the device and 4 bits for the version.

#### Boundary Scan Register

The boundary scan register contains a shift register path and a latched parallel output for all control cells and digital I/O cells.

## 10. DC ELECTRICAL CHARACTERISTICS

### ABSOLUTE MAXIMUM RATINGS

Voltage Range on Any Input, Bidirectional or Open Drain Output Lead with Respect to $V_{SS}$	-0.3V to +5.5V
Supply Voltage Range ( $V_{DD}$ ) with Respect to $V_{SS}$	-0.3V to +3.63V
Ambient Operating Temperature Range	-40°C to +85°C
Junction Operating Temperature Range	-40°C to +125°C
Storage Temperature Range	-55°C to +125°C
Soldering Temperature Range	See IPC/JEDEC J-STD-020A

Stresses beyond those listed under "Absolute Maximum Ratings" may cause permanent damage to the device. These are stress ratings only, and functional operation of the device at these or any other conditions beyond those indicated in the operational sections of the specifications is not implied. Exposure to the absolute maximum rating conditions for extended periods may affect device.

**Note:** The typical values listed in the following tables are not production tested.

**Table 10-A. Recommended DC Operating Conditions**

( $V_{DD} = 3.3V \pm 5\%$ ,  $T_A = -40^\circ\text{C}$  to  $+85^\circ\text{C}$ .)

PARAMETER	SYMBOL	CONDITIONS	MIN	TYP	MAX	UNITS
Logic 1	$V_{IH}$		2.4		5.5	V
Logic 0	$V_{IL}$		-0.3		+0.8	V
Supply	$V_{DD}$		3.135		3.465	V

**Table 10-B. DC Electrical Characteristics**

( $T_A = -40^\circ\text{C}$  to  $+85^\circ\text{C}$ )

PARAMETER	SYMBOL	CONDITIONS	MIN	TYP	MAX	UNITS
Supply Current ( $V_{DD} = 3.465V$ ) (Notes 1, 2)	$I_{DD}$	DS3146			480	mA
		DS3148			640	
		DS31412			960	
Power-Down Current (All DISABLE Bits Set) (Notes 1, 2)	$I_{DDD}$	DS3146			160	mA
		DS3148			210	
		DS31412			300	
Lead Capacitance	$C_{IO}$			7.0		pF
Input Leakage	$I_{IL}$		-10		+10	$\mu\text{A}$
Input Leakage (Inputs Pins with Internal Pullup Resistors)	$I_{ILP}$		-300		+10	$\mu\text{A}$
Output Leakage (when High-Z)	$I_{LO}$		-10		+10	$\mu\text{A}$
Output Voltage ( $I_{OH} = -4.0\text{mA}$ )	$V_{OH}$		2.4			V
Output Voltage ( $I_{OL} = +4.0\text{mA}$ )	$V_{OL}$				0.4	V

**Note 1:** DS3 mode (DS3M = 1); T1CLK, RCLK, and SCLK toggling at 44.736MHz.

**Note 2:** All outputs loaded with rated capacitance; all inputs at  $V_{DD}$  or  $V_{SS}$ ; inputs with pullups connected to  $V_{DD}$ .

## 11. AC TIMING CHARACTERISTICS

All AC timing characteristics are specified with a 50pF capacitive load on the D[7:0] and  $\overline{\text{INT}}$  pins, and a 25pF capacitive load on all other output pins,  $V_{\text{IH}} = V_{\text{DD}}$  and  $V_{\text{IL}} = V_{\text{SS}}$ . The voltage threshold for all timing measurements is  $V_{\text{DD}}/2$ .

### 11.1 System Interface Timing

**Table 11-A. Data Path Timing**

( $V_{\text{DD}} = 3.3\text{V} \pm 5\%$ ,  $T_{\text{A}} = -40^{\circ}\text{C}$  to  $+85^{\circ}\text{C}$ .) (Figure 11-1)

PARAMETER	SYMBOL	CONDITIONS	MIN	TYP	MAX	UNITS
CLK Clock Period	t1	(Note 1)	29.0	29.1		ns
		(Note 2)	22.0	22.4		
		(Note 3)	19.0	19.3		
CLK Clock Duty Cycle	t2/t1		40	50	60	%
CLK in to DIN Setup Time	t3	(Note 4)	5.0			ns
CLK in to DIN Hold Time	t4	(Note 4)	1.0			ns
CLK in to DOUT Delay	t5	(Note 5)	2.0		12	ns
CLK out to DOUT Delay	t6	(Notes 6, 7)	2.0		8.0	ns
CLK in to CLK Out Delay	t7	(Note 8)			10	ns
Asynchronous Input High, Low Time	t8, t9	(Note 9)	200			ns
Asynchronous Input Period	t10	(Note 9)	1000			ns

**Note 1:** E3 mode, nongapped 34.368MHz clock.

**Note 2:** DS3 mode, nongapped 44.736MHz clock.

**Note 3:** DS3 mode, gapped 51.84MHz clock.

**Note 4:** TICLK input to TDAT, TOH, TOHEN, and TSOF inputs; RCLK input to RPOS and RNEG inputs.

**Note 5:** TICLK input to TDEN (data-enable mode) and TSOF outputs.

**Note 6:** ROCLK output to RDAT, RDEN (data-enable mode) and RSOF outputs; TCLK output to TPOS and TNEG outputs.

**Note 7:** RGCLK (gapped clock mode) output to RDAT and RSOF outputs; TDEN/TGCLK (gapped or constant clock mode) output to TSOF output.

**Note 8:** TICLK input to TDEN/TGCLK (gapped clock or constant clock mode) outputs; RCLK input to ROCLK output.

**Note 9:** TMEI, RECU, and  $\overline{\text{RST}}$  inputs.

**Table 11-B. TCCLK Data Path Timing**

( $V_{\text{DD}} = 3.3\text{V} \pm 5\%$ ,  $T_{\text{A}} = -40^{\circ}\text{C}$  to  $+85^{\circ}\text{C}$ .) (Figure 11-2)

PARAMETER	SYMBOL	CONDITIONS	MIN	TYP	MAX	UNITS
TCCLK Clock Period	t1	(Note 10)	29	29.1		ns
		(Note 11)	22	22.4		
		(Note 12)	19	19.3		
TCCLK Clock Duty Cycle	t2/t1		40	50	60	%
TCCLK In to DIN Setup Time	t3	(Note 13)	3.0			ns
TCCLK In to DIN Hold Time	t4	(Note 13)	4.0			ns
TCCLK In to DOUT Delay	t5	(Note 14)	2.0		15	ns
TCCLK In to CLK out Delay	t7	(Note 15)			15	ns

**Note 10:** E3 mode, nongapped 34.368MHz clock.

**Note 11:** DS3 mode, nongapped 44.736MHz clock.

**Note 12:** DS3 mode, gapped 51.84MHz clock.

**Note 13:** TCCLK input to TDAT, TOH, TOHEN, and TSOF inputs.

**Note 14:** TCCLK input to TDEN/TGCLK (nonclock mode) and TSOF outputs.

**Note 15:** TCCLK input to TDEN/TGCLK (gapped clock or constant clock mode) outputs.

**Figure 11-1. Data Path Timing Diagram**

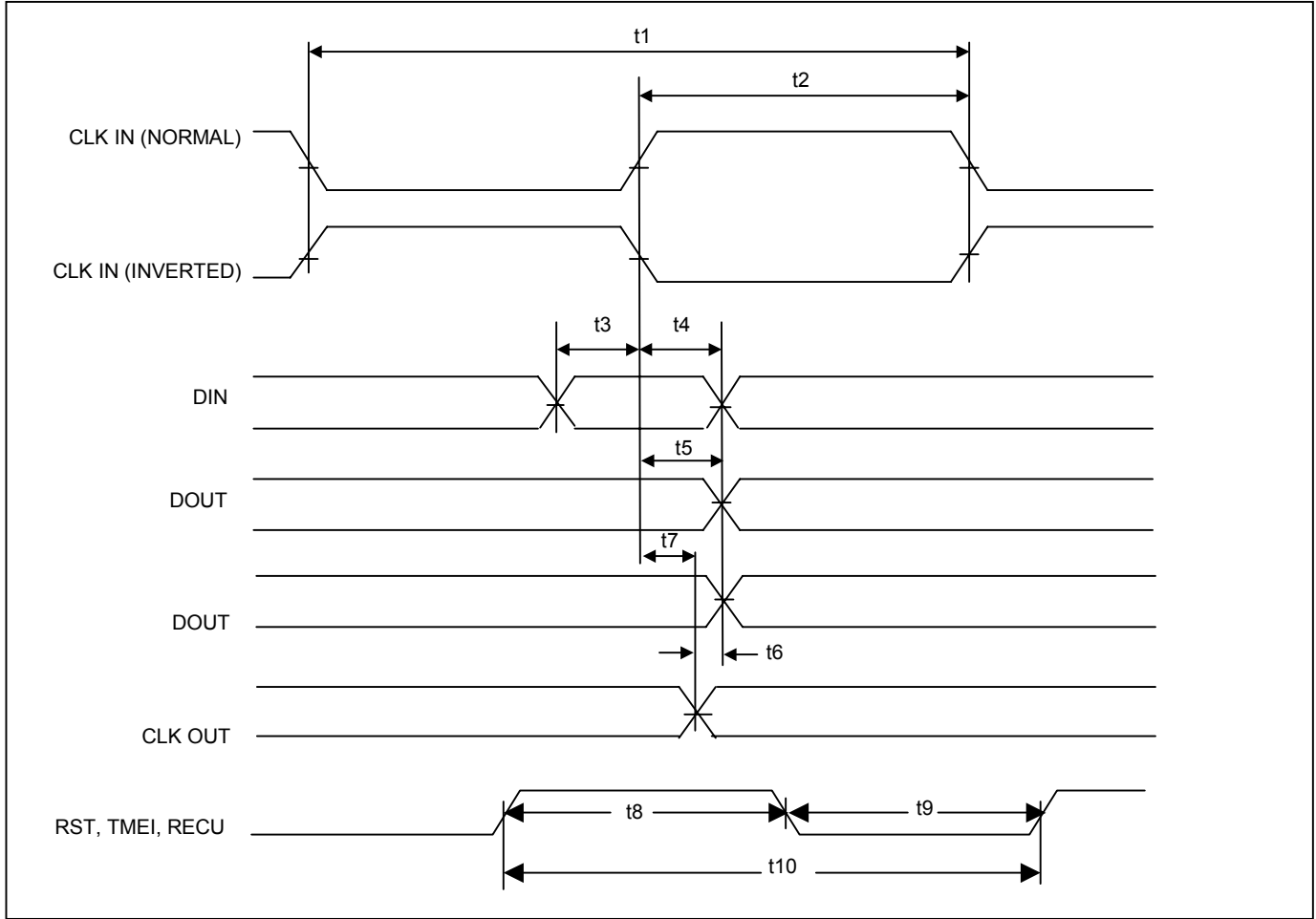

**Figure 11-2. TCCLK Data Path Timing Diagram**

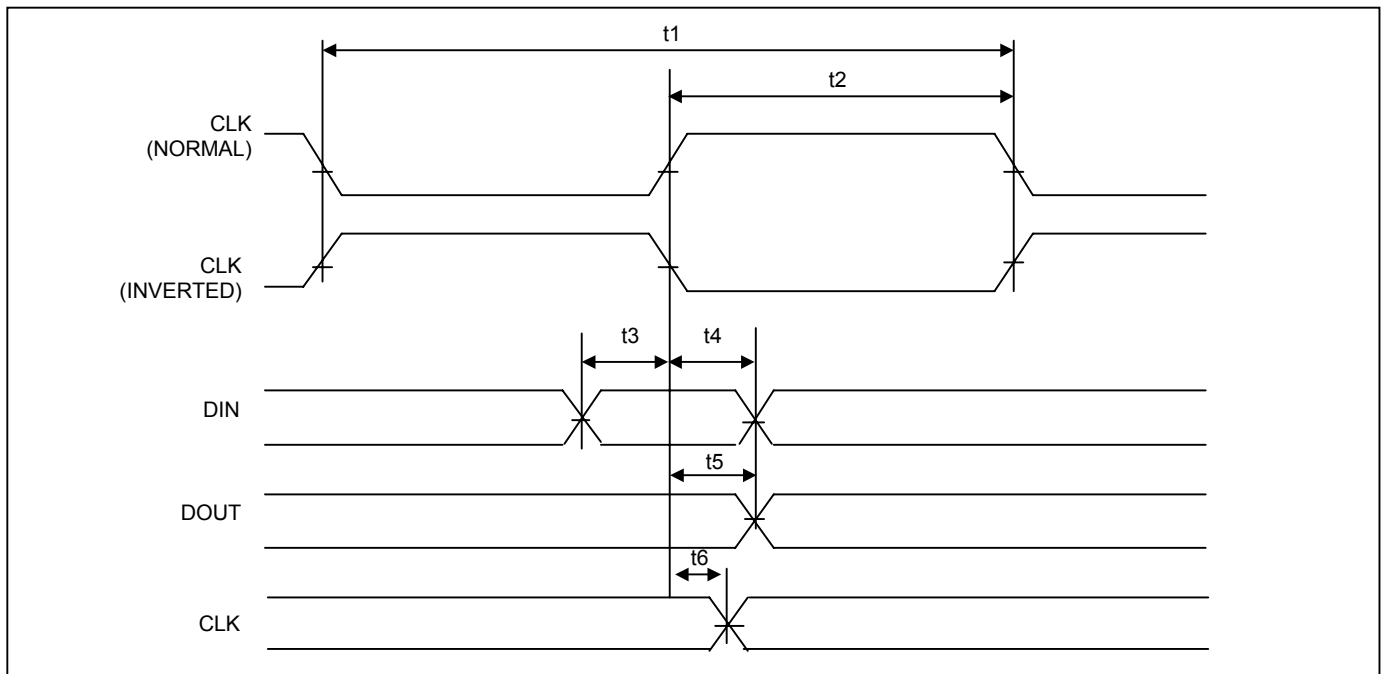
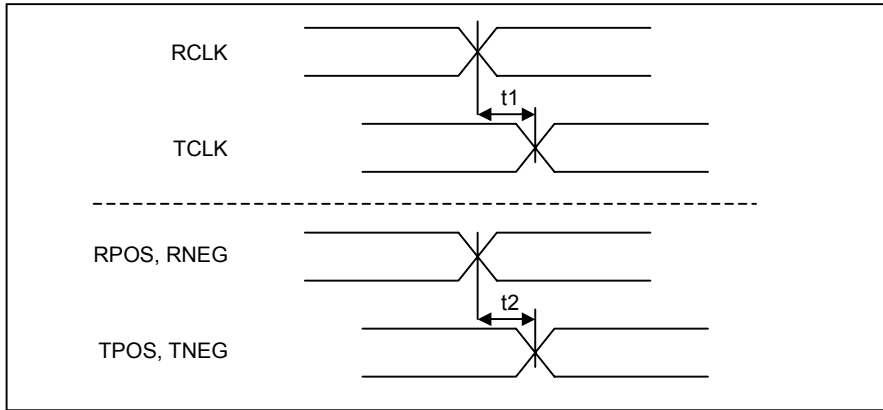

**Table 11-C. Line Loopback Timing**

( $V_{DD} = 3.3V \pm 5\%$ ,  $T_A = -40^{\circ}C$  to  $+85^{\circ}C$ .) (Figure 11-3)

PARAMETER	SYMBOL	CONDITIONS	MIN	TYP	MAX	UNITS
Skew on RPOS to TPOS Path with Respect to RCLK to TCLK Path	$t2 - t1$		0		3.0	ns
Skew on RNEG to TNEG path with Respect to RCLK to TCLK Path	$t2 - t1$		0		3.0	ns

**Figure 11-3. Line Loopback Timing Diagram**



## 11.2 Microprocessor Interface Timing

**Table 11-D. Microprocessor Interface Timing**

( $V_{DD} = 3.3V \pm 5\%$ ,  $T_A = -40^{\circ}C$  to  $+85^{\circ}C$ .) (Figure 11-4, Figure 11-5, and Figure 11-6)

PARAMETER	SYMBOL	CONDITIONS	MIN	TYP	MAX	UNITS
Setup Time for A[11:0] Valid to $\overline{CS}$ Active	t1		0			ns
Setup Time for $\overline{CS}$ Active to $\overline{RD}$ , $\overline{WR}$ , or $\overline{DS}$ Active	t2		0			ns
Delay Time from $\overline{RD}$ or $\overline{DS}$ Active to D[7:0] Valid	t3				65	ns
Hold Time from $\overline{RD}$ or $\overline{WR}$ or $\overline{DS}$ Inactive to $\overline{CS}$ Inactive	t4		0			ns
Hold Time from $\overline{CS}$ or $\overline{RD}$ or $\overline{DS}$ Inactive to D[7:0] Tri-State	t5		5.0		20	ns
Wait Time from $\overline{WR}$ or $\overline{DS}$ Active to Latch D[7:0]	t6		65			ns
D[7:0] Setup Time to $\overline{WR}$ or $\overline{DS}$ Inactive	t7		10			ns
D[7:0] Hold Time from $\overline{WR}$ or $\overline{DS}$ Inactive	t8		2.0			ns
A[11:0] Hold from $\overline{WR}$ or $\overline{RD}$ or $\overline{DS}$ Inactive	t9		5.0			ns
$\overline{RD}$ , $\overline{WR}$ , or $\overline{DS}$ Inactive Time	t10		75			ns
Muxed Address Valid to ALE Falling	t11	(Note 16)	10			ns
Muxed Address Hold Time	t12	(Note 16)	10			ns
ALE Pulse Width	t13	(Note 16)	30			ns
Setup Time for ALE High or Muxed Address Valid to $\overline{CS}$ Active	t14	(Note 16)	0			ns
SCLK Period	t15		19		31	ns
SCLK High and Low Time	t16		7.0			ns
SCLK Duty Cycle (High/Low)	t16/t15		40		60	%

**Note 16:** In nonmultiplexed bus applications (Figure 11-5), ALE should be connected high. In multiplexed bus applications (Figure 11-6), A[7:0] are normally connected to D[7:0] externally, and the falling edge of ALE latches the address.

**Note 17:** Whenever  $\overline{CS} = 0$  and  $\overline{RD} = 0$  in Intel mode or  $\overline{CS} = 0$  and  $R/\overline{WR} = 1$  and  $\overline{DS} = 0$  in Motorola mode, the bidirectional data bus D[7:0] is driven as an output.

**Figure 11-4. SCLK Clock Timing**

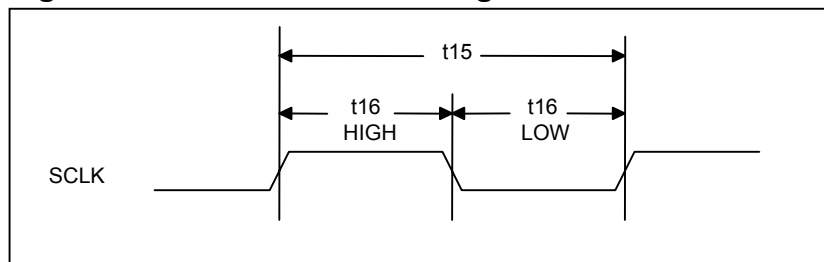

**Figure 11-5. Microprocessor Interface Timing Diagram (Nonmultiplexed)**

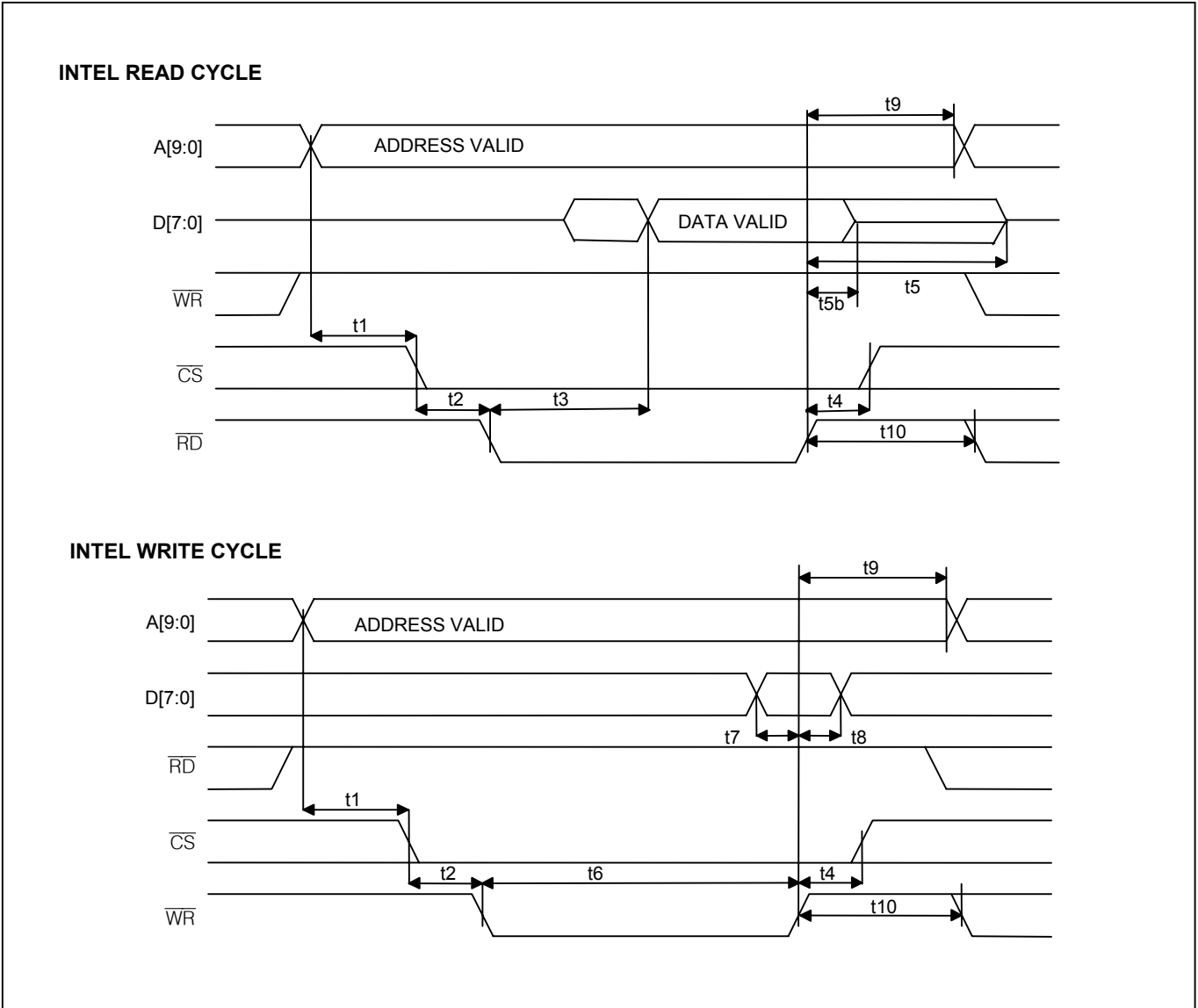

**Figure 11-5. Microprocessor Interface Timing Diagram (Nonmultiplexed) (continued)**

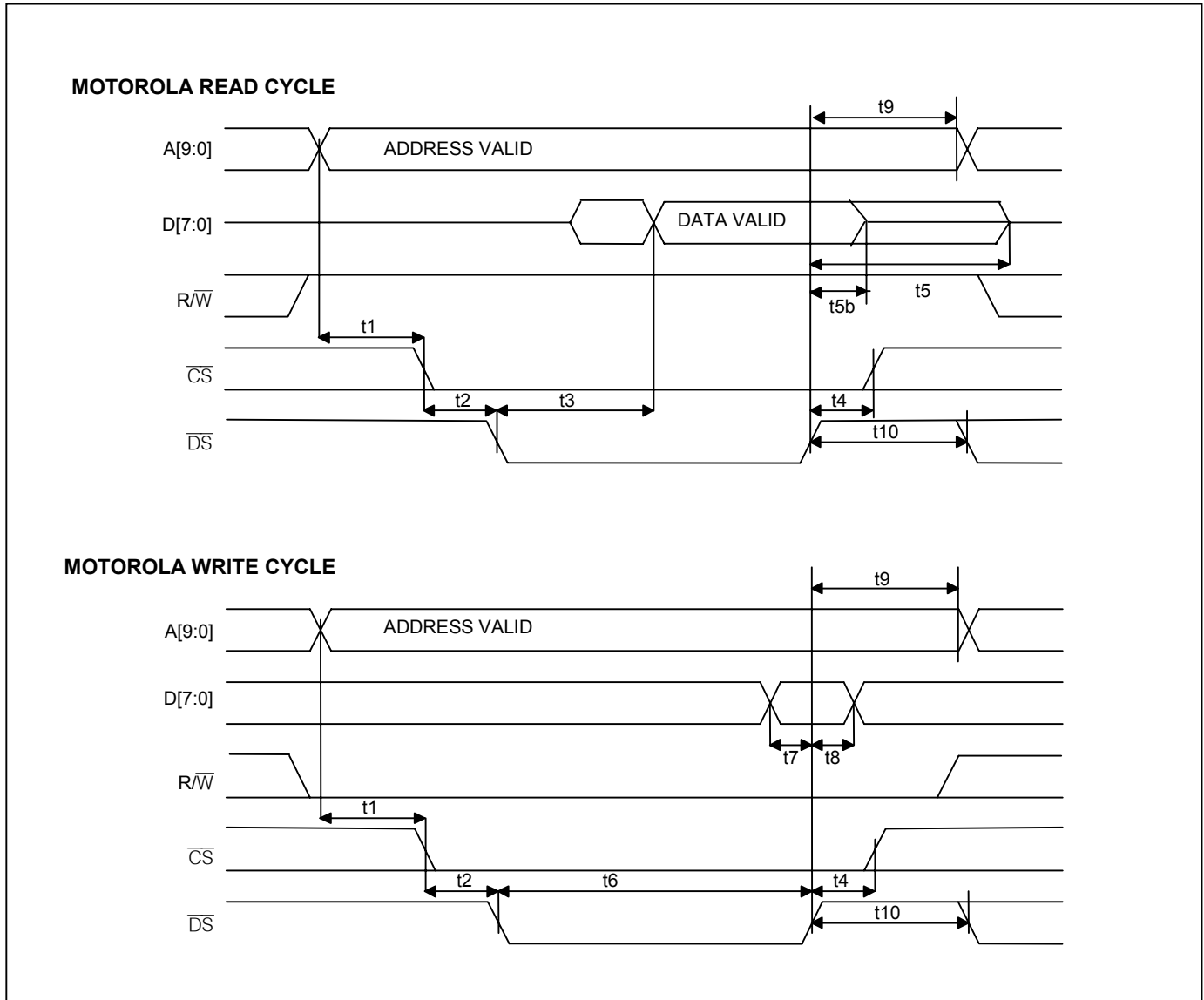



**Figure 11-6. Microprocessor Interface Timing Diagram (Multiplexed)**

**INTEL READ CYCLE**

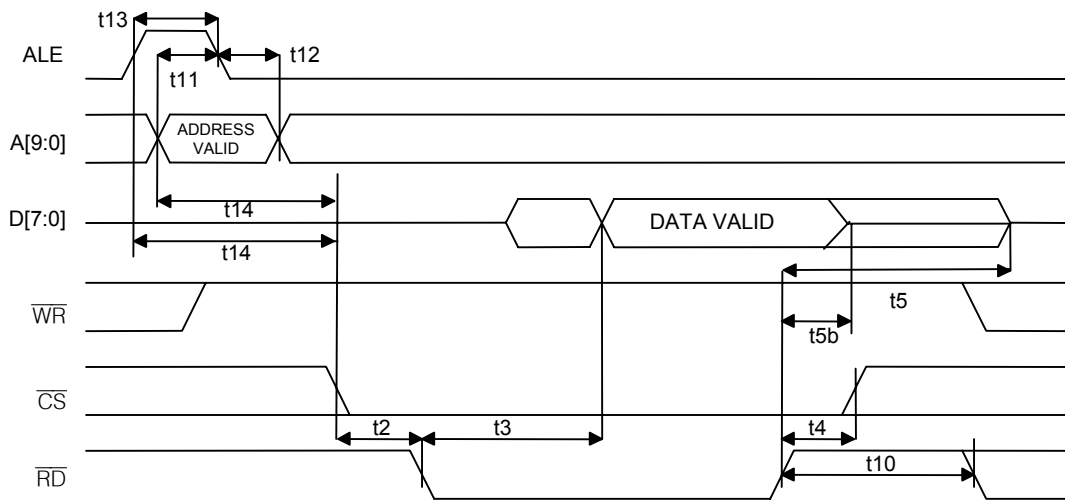

**NOTE:**  $t_{14}$  STARTS ON THE OCCURRENCE OF EITHER THE RISING EDGE OF ALE OR A VALID ADDRESS, WHICHEVER OCCURS LAST.

**INTEL WRITE CYCLE**

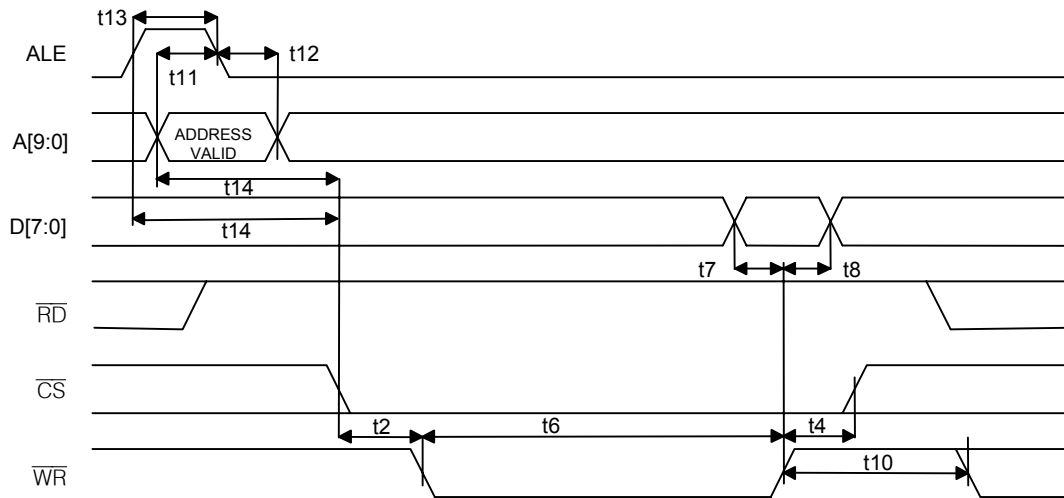

**NOTE:**  $t_{14}$  STARTS ON THE OCCURRENCE OF EITHER THE RISING EDGE OF ALE OR A VALID ADDRESS, WHICHEVER OCCURS LAST.

**Figure 11-6. Microprocessor Interface Timing Diagram (Multiplexed) (continued)**

**MOTOROLA READ CYCLE**

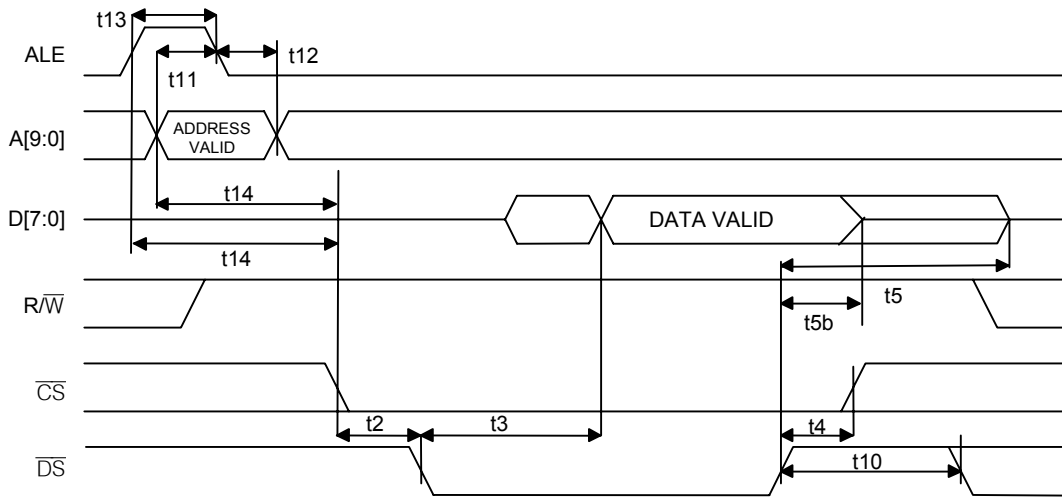

**NOTE:** t14 STARTS ON THE OCCURRENCE OF EITHER THE RISING EDGE OF ALE OR A VALID ADDRESS, WHICHEVER OCCURS LAST.

**MOTOROLA WRITE CYCLE**

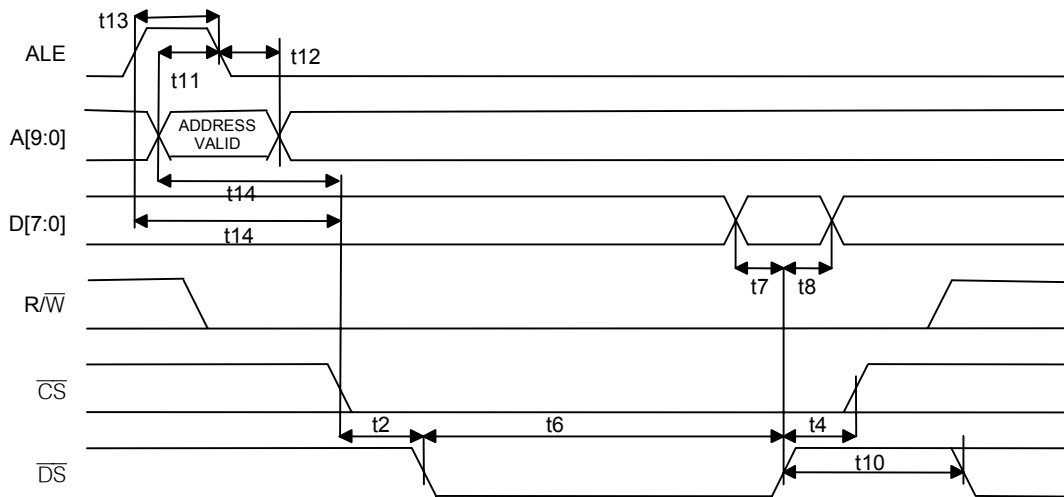

**NOTE:** t14 STARTS ON THE OCCURRENCE OF EITHER THE RISING EDGE OF ALE OR A VALID ADDRESS, WHICHEVER OCCURS LAST.

### 11.3 JTAG Interface Timing

**Table 11-E. JTAG Interface Timing**

( $V_{DD} = 3.3V \pm 5\%$ ,  $T_A = -40^{\circ}C$  to  $+85^{\circ}C$ .) (Figure 11-7)

PARAMETER	SYMBOL	CONDITIONS	MIN	TYP	MAX	UNITS
JTCLK Clock Period	t1			1000		ns
JTCLK Clock High/Low Time	t2/t3	(Note 18)	50	500		ns
JTCLK to JTDI, JTMS Setup Time	t4		50			ns
JTCLK to JTDI, JTMS Hold Time	t5		50			ns
JTCLK to JTDO Delay	t6		2		50	ns
JTCLK to JTDO High-Z Delay	t7		2		50	ns
JTRST Width Low Time	t8		100			ns

**Note 18:** Clock can be stopped high or low.

**Figure 11-7. JTAG Interface Timing Diagram**

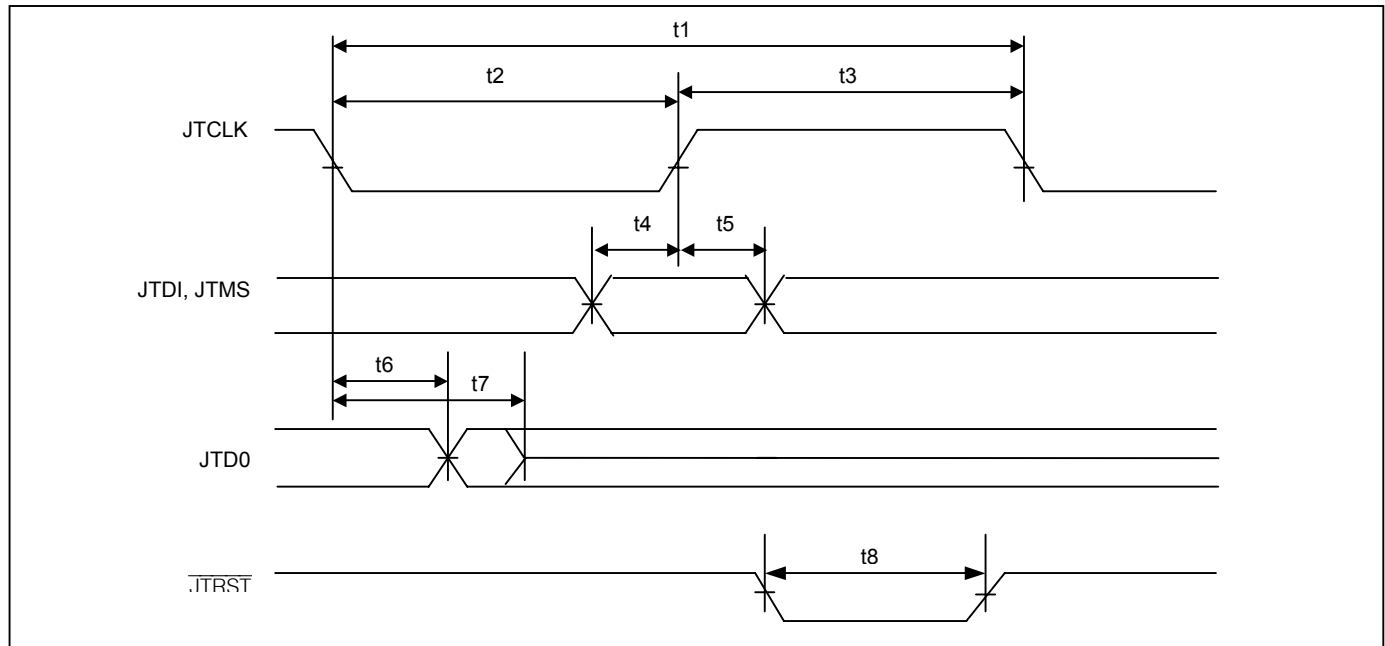

## 12. PIN ASSIGNMENTS

Table 12-A and Table 12-B list pin assignments sorted by signal name. The DS3146 only has framers 1 through 6, the DS3148 only has framers 1 through 8, and the DS31412 has all 12 framers. Figure 12-1, Figure 12-2, and Figure 12-3 show the pinouts for the three devices.

**Table 12-A. Global Pin Assignments (Sorted by Signal Name)**

NAME	PIN	NAME	PIN	NAME	PIN
A[0]	P3	$\overline{\text{CS}}$	G18	JTDO	D7
A[1]	R1	D[0]	P4	JTMS	C7
A[2]	R3	D[1]	R2	$\overline{\text{JTRST}}$	C6
A[3]	T1	D[2]	R4	MOT	E17
A[4]	T3	D[3]	T2	$\overline{\text{RD}}$	F18
A[5]	V14	D[4]	T4	RECU	B5
A[6]	Y15	D[5]	U14	$\overline{\text{RST}}$	A5
A[7]	V15	D[6]	W15	SCLK	E19
A[8]	Y16	D[7]	U15	TCCLK	E20
A[9]	W16	HIZ	D5	TCSEL	F17
A[10]	V16	$\overline{\text{INT}}$	E18	TEST	D6
A[11]	U16	JTCLK	A6	TMEI	C5
ALE	F20	JTDI	B6	$\overline{\text{WR}}$	F19

V <sub>DD</sub>	A19, B1, E6–E8, E13, E14, F6, F7, F14–F16, G5, G6, G15, G16, H5, H16, N5, N15, N16, P5, P6, P15, P16, R5, R6, R7, R14, R15, T7, T8, T13, T14, T15, W20, Y2
V <sub>SS</sub>	A1, A20, E9–E12, H8–H13, J8–J13, K–13, L9–L14, M8–M13, N8–N13, T9–T12, Y1, Y20

**Table 12-B. Per-Framer Pin Assignments (Sorted by Signal Name)**

NAME	PIN											
	FRAMER											
	1	2	3	4	5	6	7	8	9	10	11	12
RCLK	D2	N2	W4	U19	H19	B17	W13	B8	H1	Y8	N20	A3
RDAT	D1	N4	Y4	U20	H17	A17	U13	D8	J3	V9	M18	C12
RDEN/RGCLK	E4	P1	U5	T17	G20	D16	Y14	A7	J2	W9	M19	B12
RLOS	E5	M2	T5	T16	J19	D16	W12	B9	G1	Y7	P20	A14
RNEG/RLCV	C2	M3	W3	V19	J18	B18	V12	C9	H4	U8	N17	D13
ROCLK	E3	P2	V5	T18	G19	C16	W14	B7	J1	Y9	M20	A12
ROOF	F5	N1	T6	R16	H20	E15	Y13	A8	H2	W8	N19	B13
RPOS/RNRZ	D3	M4	V4	U18	J17	C17	U12	D9	H3	V8	N18	C13
RSOF	C1	N3	Y3	V20	H18	A18	V13	C8	J4	U9	M17	D12
TCLK	A2	L2	W1	Y19	K19	B20	W11	B10	F1	Y6	R20	A15
TDAT	D4	K1	U4	U17	L20	D17	Y10	A11	F3	V6	R18	C15
TDEN/TGCLK	A3	L1	V1	Y18	K20	C20	Y11	A10	F2	W6	R19	B15
TICLK	C4	K2	U3	V17	L19	D18	W10	B11	F4	U6	R17	D15
TNEG	B2	L4	W2	W19	K17	B19	U11	D10	G3	V7	P18	C14
TOH	B4	K3	U2	W17	L18	D19	V10	C11	E1	Y5	T20	A16
TOHEN	A4	K4	U1	Y17	L17	D20	U10	D11	E2	W5	T19	B16
TPOS/TNRZ	C3	M1	V3	V18	J20	C18	Y12	A9	G2	W7	P19	B14
TSOF	B3	L3	V2	W18	K18	C19	V11	C10	G4	U7	P17	D14

Figure 12-1. DS3146 Pin Configuration

	1	2	3	4	5	6	7	8	9	10	11	12	13	14	15	16	17	18	19	20			
<b>A</b>	V <sub>SS</sub>	TCLK 1	TDEN 1	TOHEN 1	RST	JTCLK	N.C.	N.C.	N.C.	N.C.	N.C.	N.C.	N.C.	N.C.	N.C.	N.C.	RDAT 6	RSOF 6	V <sub>DD</sub>	V <sub>SS</sub>			
<b>B</b>	V <sub>DD</sub>	TNEG 1	TSOF 1	TOH 1	RECU	JTDI	N.C.	N.C.	N.C.	N.C.	N.C.	N.C.	N.C.	N.C.	N.C.	N.C.	RCLK 6	RNEG 6	TNEG 6	TCLK 6			
<b>C</b>	RSOF 1	RNEG 1	TPOS 1	TICLK 1	TMEI	JTRST	JTMS	N.C.	N.C.	N.C.	N.C.	N.C.	N.C.	N.C.	N.C.	N.C.	ROCLK 6	RPOS 6	TPOS 6	TSOF 6	TDEN 6		
<b>D</b>	RDAT 1	RCLK 1	RPOS 1	TDAT 1	HIZ	TEST	JTDO	N.C.	N.C.	N.C.	N.C.	N.C.	N.C.	N.C.	N.C.	N.C.	RDEN 6	TDAT 6	TICLK 6	TOH 6	TOHEN 6		
<b>E</b>	N.C.	N.C.	ROCLK 1	RDEN 1	RLOS 1	V <sub>DD</sub>	V <sub>DD</sub>	V <sub>DD</sub>	V <sub>SS</sub>	V <sub>SS</sub>	V <sub>SS</sub>	V <sub>SS</sub>	V <sub>DD</sub>	V <sub>DD</sub>	ROOF 6	RLOS 6	MOT	INT	SCLK	TCCLK			
<b>F</b>	N.C.	N.C.	N.C.	N.C.	ROOF 1	V <sub>DD</sub>	V <sub>DD</sub>								V <sub>DD</sub>	V <sub>DD</sub>	V <sub>DD</sub>	TCSEL	R <sub>D</sub>	WR	ALE		
<b>G</b>	N.C.	N.C.	N.C.	N.C.	V <sub>DD</sub>	V <sub>DD</sub>									V <sub>DD</sub>	V <sub>DD</sub>	NC	CS	ROCLK 5	RDEN 5			
<b>H</b>	N.C.	N.C.	N.C.	N.C.	V <sub>DD</sub>			V <sub>SS</sub>	V <sub>SS</sub>	V <sub>SS</sub>	V <sub>SS</sub>	V <sub>SS</sub>	V <sub>SS</sub>	V <sub>SS</sub>			V <sub>DD</sub>	RDAT 5	RSOF 5	RCLK 5	ROOF 5		
<b>J</b>	N.C.	N.C.	N.C.	N.C.	V <sub>SS</sub>			V <sub>SS</sub>	V <sub>SS</sub>	V <sub>SS</sub>	V <sub>SS</sub>	V <sub>SS</sub>	V <sub>SS</sub>	V <sub>SS</sub>			V <sub>SS</sub>	RPOS 5	RNEG 5	RLOS 5	TPOS 5		
<b>K</b>	TDAT 2	TICLK 2	TOH 2	TOHEN 2	V <sub>SS</sub>			V <sub>SS</sub>	V <sub>SS</sub>	V <sub>SS</sub>	V <sub>SS</sub>	V <sub>SS</sub>	V <sub>SS</sub>	V <sub>SS</sub>			V <sub>SS</sub>	TNEG 5	TSOF 5	TCLK 5	TDEN 5		
<b>L</b>	TDEN 2	TCLK 2	TSOF 2	TNEG 2	V <sub>SS</sub>			V <sub>SS</sub>	V <sub>SS</sub>	V <sub>SS</sub>	V <sub>SS</sub>	V <sub>SS</sub>	V <sub>SS</sub>	V <sub>SS</sub>			V <sub>SS</sub>	TOHEN 5	TOH 5	TICLK 5	TDAT 5		
<b>M</b>	TPOS 2	RLOS 2	RNEG 2	RPOS 2	V <sub>SS</sub>			V <sub>SS</sub>	V <sub>SS</sub>	V <sub>SS</sub>	V <sub>SS</sub>	V <sub>SS</sub>	V <sub>SS</sub>	V <sub>SS</sub>			V <sub>SS</sub>	N.C.	N.C.	N.C.	N.C.		
<b>N</b>	ROOF 2	RCLK 2	RSOF 2	RDAT 2	V <sub>DD</sub>			V <sub>SS</sub>	V <sub>SS</sub>	V <sub>SS</sub>	V <sub>SS</sub>	V <sub>SS</sub>	V <sub>SS</sub>	V <sub>SS</sub>			V <sub>DD</sub>	V <sub>DD</sub>	N.C.	N.C.	N.C.	N.C.	
<b>P</b>	RDEN 2	ROCLK 2	A[0]	D[0]	V <sub>DD</sub>	V <sub>DD</sub>											V <sub>DD</sub>	V <sub>DD</sub>	N.C.	N.C.	N.C.	N.C.	
<b>R</b>	A[1]	D[1]	A[2]	D[2]	V <sub>DD</sub>	V <sub>DD</sub>	V <sub>DD</sub>								V <sub>DD</sub>	V <sub>DD</sub>	ROOF 4	N.C.	N.C.	N.C.	N.C.		
<b>T</b>	A[3]	D[3]	A[4]	D[4]	RLOS 3	ROOF 3	V <sub>DD</sub>	V <sub>DD</sub>	V <sub>SS</sub>	V <sub>SS</sub>	V <sub>SS</sub>	V <sub>SS</sub>	V <sub>DD</sub>	V <sub>DD</sub>	V <sub>DD</sub>	V <sub>DD</sub>	RLOS 4	RDEN 4	ROCLK 4	N.C.	N.C.		
<b>U</b>	TOHEN 3	TOH 3	TICLK 3	TDAT 3	RDEN 3	N.C.	N.C.	N.C.	N.C.	N.C.	N.C.	N.C.	N.C.	N.C.	N.C.	N.C.	D[5]	D[7]	A[11]	TDAT 4	RPOS 4	RCLK 4	RDAT 4
<b>V</b>	TDEN 3	TSOF 3	TPOS 3	RPOS 3	ROCLK 3	N.C.	N.C.	N.C.	N.C.	N.C.	N.C.	N.C.	N.C.	N.C.	N.C.	N.C.	A[5]	A[7]	A[10]	TICLK 4	TPOS 4	RNEG 4	RSOF 4
<b>W</b>	TCLK 3	TNEG 3	RNEG 3	RCLK 3	N.C.	N.C.	N.C.	N.C.	N.C.	N.C.	N.C.	N.C.	N.C.	N.C.	N.C.	N.C.	D[6]	A[9]	TOH 4	TSOF 4	TNEG 4	V <sub>DD</sub>	
<b>Y</b>	V <sub>SS</sub>	V <sub>DD</sub>	RSOF 3	RDAT 3	N.C.	N.C.	N.C.	N.C.	N.C.	N.C.	N.C.	N.C.	N.C.	N.C.	N.C.	N.C.	A[6]	A[8]	TOHEN 4	TDEN 4	TCLK 4	V <sub>SS</sub>	

	Framer Pins
	Global Pins
	V <sub>DD</sub>
	V <sub>SS</sub>

Figure 12-2. DS3148 Pin Configuration

	1	2	3	4	5	6	7	8	9	10	11	12	13	14	15	16	17	18	19	20	
<b>A</b>	V <sub>SS</sub>	TCLK 1	TDEN 1	TOHEN 1	RST	JTCLK	RDEN 8	ROOF 8	TPOS 8	TDEN 8	TDAT 8	N.C.	N.C.	N.C.	N.C.	N.C.	RDAT 6	RSOF 6	V <sub>DD</sub>	V <sub>SS</sub>	
<b>B</b>	V <sub>DD</sub>	TNEG 1	TSOF 1	TOH 1	RECU	JTDI	ROCLK 8	RCLK 8	RLOS 8	TCLK 8	TICLK 8	N.C.	N.C.	N.C.	N.C.	N.C.	RCLK 6	RNEG 6	TNEG 6	TCLK 6	
<b>C</b>	RSOF 1	RNEG 1	TPOS 1	TICLK 1	TMEI	JTRST	JTMS	RSOF 8	RNEG 8	TSOF 8	TOH 8	N.C.	N.C.	N.C.	N.C.	ROCLK 6	RPOS 6	TPOS 6	TSOF 6	TDEN 6	
<b>D</b>	RDAT 1	RCLK 1	RPOS 1	TDAT 1	HIZ	TEST	JTDO	RDAT 8	RPOS 8	TNEG 8	TOHEN 8	N.C.	N.C.	N.C.	N.C.	RDEN 6	TDAT 6	TICLK 6	TOH 6	TOHEN 6	
<b>E</b>	N.C.	N.C.	ROCLK 1	RDEN 1	RLOS 1	V <sub>DD</sub>	V <sub>DD</sub>	V <sub>DD</sub>	V <sub>SS</sub>	V <sub>SS</sub>	V <sub>SS</sub>	V <sub>SS</sub>	V <sub>DD</sub>	V <sub>DD</sub>	ROOF 6	RLOS 6	MOT	INT	SCLK	TCCLK	
<b>F</b>	N.C.	N.C.	N.C.	N.C.	ROOF 1	V <sub>DD</sub>	V <sub>DD</sub>							V <sub>DD</sub>	V <sub>DD</sub>	V <sub>DD</sub>	TCSEL	R <sub>D</sub>	WR	ALE	
<b>G</b>	N.C.	N.C.	N.C.	N.C.	V <sub>DD</sub>	V <sub>DD</sub>									V <sub>DD</sub>	V <sub>DD</sub>	NC	CS	ROCLK 5	RDEN 5	
<b>H</b>	N.C.	N.C.	N.C.	N.C.	V <sub>DD</sub>			V <sub>SS</sub>	V <sub>SS</sub>	V <sub>SS</sub>	V <sub>SS</sub>	V <sub>SS</sub>	V <sub>SS</sub>			V <sub>DD</sub>	RDAT 5	RSOF 5	RCLK 5	ROOF 5	
<b>J</b>	N.C.	N.C.	N.C.	N.C.	V <sub>SS</sub>			V <sub>SS</sub>	V <sub>SS</sub>	V <sub>SS</sub>	V <sub>SS</sub>	V <sub>SS</sub>	V <sub>SS</sub>			V <sub>SS</sub>	RPOS 5	RNEG 5	RLOS 5	TPOS 5	
<b>K</b>	TDAT 2	TICLK 2	TOH 2	TOHEN 2	V <sub>SS</sub>			V <sub>SS</sub>	V <sub>SS</sub>	V <sub>SS</sub>	V <sub>SS</sub>	V <sub>SS</sub>	V <sub>SS</sub>			V <sub>SS</sub>	TNEG 5	TSOF 5	TCLK 5	TDEN 5	
<b>L</b>	TDEN 2	TCLK 2	TSOF 2	TNEG 2	V <sub>SS</sub>			V <sub>SS</sub>	V <sub>SS</sub>	V <sub>SS</sub>	V <sub>SS</sub>	V <sub>SS</sub>	V <sub>SS</sub>			V <sub>SS</sub>	TOHEN 5	TOH 5	TICLK 5	TDAT 5	
<b>M</b>	TPOS 2	RLOS 2	RNEG 2	RPOS 2	V <sub>SS</sub>			V <sub>SS</sub>	V <sub>SS</sub>	V <sub>SS</sub>	V <sub>SS</sub>	V <sub>SS</sub>	V <sub>SS</sub>			V <sub>SS</sub>	N.C.	N.C.	N.C.	N.C.	
<b>N</b>	ROOF 2	RCLK 2	RSOF 2	RDAT 2	V <sub>DD</sub>			V <sub>SS</sub>	V <sub>SS</sub>	V <sub>SS</sub>	V <sub>SS</sub>	V <sub>SS</sub>	V <sub>SS</sub>			V <sub>DD</sub>	V <sub>DD</sub>	N.C.	N.C.	N.C.	N.C.
<b>P</b>	RDEN 2	ROCLK 2	A[0]	D[0]	V <sub>DD</sub>	V <sub>DD</sub>										V <sub>DD</sub>	V <sub>DD</sub>	N.C.	N.C.	N.C.	N.C.
<b>R</b>	A[1]	D[1]	A[2]	D[2]	V <sub>DD</sub>	V <sub>DD</sub>	V <sub>DD</sub>							V <sub>DD</sub>	V <sub>DD</sub>	V <sub>DD</sub>	ROOF 4	N.C.	N.C.	N.C.	N.C.
<b>T</b>	A[3]	D[3]	A[4]	D[4]	RLOS 3	ROOF 3	V <sub>DD</sub>	V <sub>DD</sub>	V <sub>SS</sub>	V <sub>SS</sub>	V <sub>SS</sub>	V <sub>SS</sub>	V <sub>DD</sub>	V <sub>DD</sub>	V <sub>DD</sub>	V <sub>DD</sub>	RLOS 4	RDEN 4	ROCLK 4	N.C.	N.C.
<b>U</b>	TOHEN 3	TOH 3	TICLK 3	TDAT 3	RDEN 3	N.C.	N.C.	N.C.	N.C.	TOHEN 7	TNEG 7	RPOS 7	RDAT 7	D[5]	D[7]	A[11]	TDAT 4	RPOS 4	RCLK 4	RDAT 4	
<b>V</b>	TDEN 3	TSOF 3	TPOS 3	RPOS 3	ROCLK 3	N.C.	N.C.	N.C.	N.C.	TOH 7	TSOF 7	RNEG 7	RSOF 7	A[5]	A[7]	A[10]	TICLK 4	TPOS 4	RNEG 4	RSOF 4	
<b>W</b>	TCLK 3	TNEG 3	RNEG 3	RCLK 3	N.C.	N.C.	N.C.	N.C.	N.C.	TICLK 7	TCLK 7	RLOS 7	RCLK 7	ROCLK 7	D[6]	A[9]	TOH 4	TSOF 4	TNEG 4	V <sub>DD</sub>	
<b>Y</b>	V <sub>SS</sub>	V <sub>DD</sub>	RSOF 3	RDAT 3	N.C.	N.C.	N.C.	N.C.	N.C.	TDAT 7	TDEN 7	TPOS 7	ROOF 7	RDEN 7	A[6]	A[8]	TOHEN 4	TDEN 4	TCLK 4	V <sub>SS</sub>	

	Framer Pins
	Global Pins
	V <sub>DD</sub>
	V <sub>SS</sub>

Figure 12-3. DS31412 Pin Configuration

	1	2	3	4	5	6	7	8	9	10	11	12	13	14	15	16	17	18	19	20	
<b>A</b>	V <sub>SS</sub>	TCLK 1	TDEN 1	TOHEN 1	RST	JTCLK	RDEN 8	ROOF 8	TPOS 8	TDEN 8	TDAT 8	ROCLK 12	RCLK 12	RLOS 12	TCLK 12	TOH 12	RDAT 6	RSOF 6	V <sub>DD</sub>	V <sub>SS</sub>	
<b>B</b>	V <sub>DD</sub>	TNEG 1	TSOF 1	TOH 1	RECU	JTDI	ROCLK 8	RCLK 8	RLOS 8	TCLK 8	TICKL 8	RDEN 12	ROOF 12	TPOS 12	TDEN 12	TOHEN 12	RCLK 6	RNEG 6	TNEG 6	TCLK 6	
<b>C</b>	RSOF 1	RNEG 1	TPOS 1	TICKL 1	TMEI	JTRST	JTMS	RSOF 8	RNEG 8	TSOF 8	TOH 8	RDAT 12	RPOS 12	TNEG 12	TDAT 12	ROCLK 6	RPOS 6	TPOS 6	TSOF 6	TDEN 6	
<b>D</b>	RDAT 1	RCLK 1	RPOS 1	TDAT 1	HIZ	TEST	JTDO	RDAT 8	RPOS 8	TNEG 8	TOHEN 8	RSOF 12	RNEG 12	TSOF 12	TICKL 12	RDEN 6	TDAT 6	TICKL 6	TOH 6	TOHEN 6	
<b>E</b>	TOH 9	TOHEN 9	ROCLK 9	RDEN 9	RLOS 1	V <sub>DD</sub>	V <sub>DD</sub>	V <sub>DD</sub>	V <sub>SS</sub>	V <sub>SS</sub>	V <sub>SS</sub>	V <sub>SS</sub>	V <sub>DD</sub>	V <sub>DD</sub>	ROOF 6	RLOS 6	MOT	INT	SCLK	TCCLK	
<b>F</b>	TCLK 9	TDEN 9	TDAT 9	TICKL 9	ROOF 1	V <sub>DD</sub>	V <sub>DD</sub>							V <sub>DD</sub>	V <sub>DD</sub>	V <sub>DD</sub>	TCSEL	R <sub>D</sub>	WR	ALE	
<b>G</b>	RLOS 9	TPOS 9	TNEG 9	TSOF 9	V <sub>DD</sub>	V <sub>DD</sub>									V <sub>DD</sub>	V <sub>DD</sub>	N.C.	CS	ROCLK 5	RDEN 5	
<b>H</b>	RCLK 9	ROOF 9	RPOS 9	RNEG 9	V <sub>DD</sub>			V <sub>SS</sub>	V <sub>SS</sub>	V <sub>SS</sub>	V <sub>SS</sub>	V <sub>SS</sub>	V <sub>SS</sub>			V <sub>DD</sub>	RDAT 5	RSOF 5	RCLK 5	ROOF 5	
<b>J</b>	ROCLK 9	RDEN 9	RDAT 9	RSOF 9	V <sub>SS</sub>			V <sub>SS</sub>	V <sub>SS</sub>	V <sub>SS</sub>	V <sub>SS</sub>	V <sub>SS</sub>	V <sub>SS</sub>			V <sub>SS</sub>	RPOS 5	RNEG 5	RLOS 5	TPOS 5	
<b>K</b>	TDAT 2	TICKL 2	TOH 2	TOHEN 2	V <sub>SS</sub>			V <sub>SS</sub>	V <sub>SS</sub>	V <sub>SS</sub>	V <sub>SS</sub>	V <sub>SS</sub>	V <sub>SS</sub>			V <sub>SS</sub>	TNEG 5	TSOF 5	TCLK 5	TDEN 5	
<b>L</b>	TDEN 2	TCLK 2	TSOF 2	TNEG 2	V <sub>SS</sub>			V <sub>SS</sub>	V <sub>SS</sub>	V <sub>SS</sub>	V <sub>SS</sub>	V <sub>SS</sub>	V <sub>SS</sub>			V <sub>SS</sub>	TOHEN 5	TOH 5	TICKL 5	TDAT 5	
<b>M</b>	TPOS 2	RLOS 2	RNEG 2	RPOS 2	V <sub>SS</sub>			V <sub>SS</sub>	V <sub>SS</sub>	V <sub>SS</sub>	V <sub>SS</sub>	V <sub>SS</sub>	V <sub>SS</sub>			V <sub>SS</sub>	RSOF 11	RDAT 11	RDEN 11	ROCLK 11	
<b>N</b>	ROOF 2	RCLK 2	RSOF 2	RDAT 2	V <sub>DD</sub>			V <sub>SS</sub>	V <sub>SS</sub>	V <sub>SS</sub>	V <sub>SS</sub>	V <sub>SS</sub>	V <sub>SS</sub>			V <sub>DD</sub>	V <sub>DD</sub>	RNEG 11	RPOS 11	ROOF 11	RCLK 11
<b>P</b>	RDEN 2	ROCLK 2	A[0]	D[0]	V <sub>DD</sub>	V <sub>DD</sub>										V <sub>DD</sub>	V <sub>DD</sub>	TSOF 11	TNEG 11	TPOS 11	RLOS 11
<b>R</b>	A[1]	D[1]	A[2]	D[2]	V <sub>DD</sub>	V <sub>DD</sub>	V <sub>DD</sub>							V <sub>DD</sub>	V <sub>DD</sub>	V <sub>DD</sub>	ROOF 4	TICKL 11	TDAT 11	TDEN 11	TCLK 11
<b>T</b>	A[3]	D[3]	A[4]	D[4]	RLOS 3	ROOF 3	V <sub>DD</sub>	V <sub>DD</sub>	V <sub>SS</sub>	V <sub>SS</sub>	V <sub>SS</sub>	V <sub>SS</sub>	V <sub>DD</sub>	V <sub>DD</sub>	V <sub>DD</sub>	V <sub>DD</sub>	RLOS 4	RDEN 4	ROCLK 4	TOHEN 11	TOH 11
<b>U</b>	TOHEN 3	TOH 3	TICKL 3	TDAT 3	RDEN 3	TICKL 10	TSOF 10	RNEG 10	RSOF 10	TOHEN 7	TNEG 7	RPOS 7	RDAT 7	D[5]	D[7]	A[11]	TDAT 4	RPOS 4	RCLK 4	RDAT 4	
<b>V</b>	TDEN 3	TSOF 3	TPOS 3	RPOS 3	ROCLK 3	TDAT 10	TNEG 10	RPOS 10	RDAT 10	TOH 7	TSOF 7	RNEG 7	RSOF 7	A[5]	A[7]	A[10]	TICKL 4	TPOS 4	RNEG 4	RSOF 4	
<b>W</b>	TCLK 3	TNEG 3	RNEG 3	RCLK 3	TOHEN 10	TDEN 10	TPOS 10	ROOF 10	RDEN 10	TICKL 7	TCLK 7	RLOS 7	RCLK 7	ROCLK 7	D[6]	A[9]	TOH 4	TSOF 4	TNEG 4	V <sub>DD</sub>	
<b>Y</b>	V <sub>SS</sub>	V <sub>DD</sub>	RSOF 3	RDAT 3	TOH 10	TCLK 10	RLOS 10	RCLK 10	ROCLK 10	TDAT 7	TDEN 7	TPOS 7	ROOF 7	RDEN 7	A[6]	A[8]	TOHEN 4	TDEN 4	TCLK 4	V <sub>SS</sub>	

	Framer Pins
	Global Pins
	V <sub>DD</sub>
	V <sub>SS</sub>

### 13. PACKAGE INFORMATION

(The package drawing(s) in this data sheet may not reflect the most current specifications. For the latest package outline information, go to [www.maxim-ic.com/DallasPackInfo](http://www.maxim-ic.com/DallasPackInfo).)

**Note:** All dimensions in millimeters. Integrated metal heat spreader.

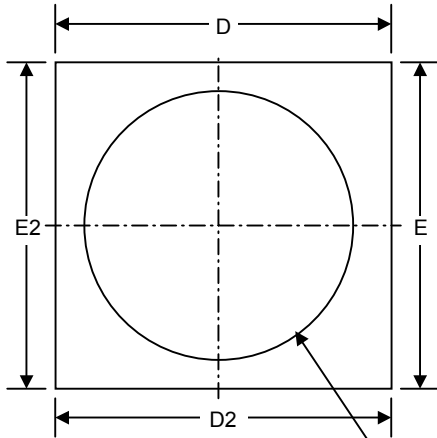

EXPOSED HEAT SPREADER

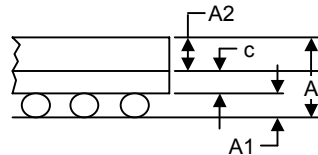
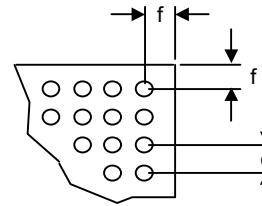
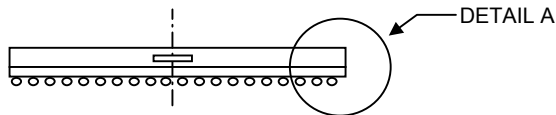
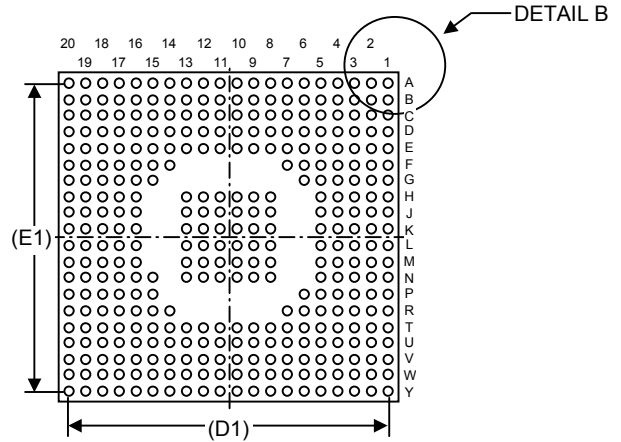

REF	MIN	NOM	MAX
A	1.95	2.15	2.35
A1	0.50	0.60	0.70
A2	0.95	1.00	1.05
D	26.80	27.00	27.20
D1	25.00 BSC.		
D2	26.80	27.00	27.20
E	26.80	27.00	27.20
E1	25.00 BSC.		
E2	26.80	27.00	27.20
b	0.60	0.75	0.90
c	0.50	0.55	0.60
aaa			0.20
bbb			0.25
ccc			0.35
e	1.27 BSC.		
f	1.34	1.44	1.54
M	20		
N	349		

**349-Lead TE-PBGA-2**



## 14. THERMAL INFORMATION

**Table 14-A. Thermal Properties, Natural Convection**

PARAMETER	SYMBOL	CONDITIONS	MIN	TYP	MAX	UNITS
Ambient Temperature		(Note 1)	-40.0		+85.0	°C
Junction Temperature			-40.0		+125	°C
Theta-JA ( $\theta_{JA}$ ), Still Air		(Note 2)		12.69		°C/W
Psi-JB				3.86		°C/W
Psi-JT				1.24		°C/W

**Note 1:** The package is mounted on a four-layer JEDEC standard test board with no airflow and dissipating maximum power.

**Note 2:** Theta-JA ( $\theta_{JA}$ ) is the junction to ambient thermal resistance, when the package is mounted on a four-layer JEDEC standard test board with no airflow and dissipating maximum power.

**Table 14-B. Theta-JA ( $\theta_{JA}$ ) vs. Airflow**

FORCED AIR (m/s)	THETA-JA ( $\theta_{JA}$ )
0	12.69°C/W
1	9.13°C/W
2.5	7.33°C/W

## 15. REVISION HISTORY

REVISION	DESCRIPTION
042203	DS31412 new product release.
071103	DS3146, DS3148 new product releases.

*Maxim/Dallas Semiconductor cannot assume responsibility for use of any circuitry other than circuitry entirely embodied in a Maxim/Dallas Semiconductor product. No circuit patent licenses are implied. Maxim/Dallas Semiconductor reserves the right to change the circuitry and specifications without notice at any time.*

**Maxim Integrated Products, 120 San Gabriel Drive, Sunnyvale, CA 94086 408-737-7600**

© 2003 Maxim Integrated Products • Printed USA